



EPIA-P700

User's Manual

Version 1.04
November 14, 2008

Copyright

Copyright © 2008 VIA Technologies Incorporated. All rights reserved.

No part of this document may be reproduced, transmitted, transcribed, stored in a retrieval system, or translated into any language, in any form or by any means, electronic, mechanical, magnetic, optical, chemical, manual or otherwise without the prior written permission of VIA Technologies, Incorporated.

Trademarks

All trademarks are the property of their respective holders. PS/2 is a registered trademark of IBM Corporation.

Disclaimer

No license is granted, implied or otherwise, under any patent or patent rights of VIA Technologies. VIA Technologies makes no warranties, implied or otherwise, in regard to this document and to the products described in this document. The information provided in this document is believed to be accurate and reliable as of the publication date of this document. However, VIA Technologies assumes no responsibility for the use or misuse of the information in this document and for any patent infringements that may arise from the use of this document. The information and product specifications within this document are subject to change at any time, without notice and without obligation to notify any person of such change.

FCC-B Radio Frequency Interference Statement

This equipment has been tested and found to comply with the limits for a class B digital device, pursuant to part 15 of the FCC rules. These limits are designed to provide reasonable protection against harmful interference when the equipment is operated in a commercial environment. This equipment generates, uses and can radiate radio frequency energy and, if not installed and used in accordance with the instruction manual, may cause harmful interference to radio communications. Operation of this equipment in a residential area is likely to cause harmful interference, in which case the user will be required to correct the interference at his personal expense.

Notice 1

The changes or modifications not expressly approved by the party responsible for compliance could void the user's authority to operate the equipment.

Notice 2

Shielded interface cables and A.C. power cord, if any, must be used in order to comply with the emission limits.



Tested To Comply
With FCC Standards
FOR HOME OR OFFICE USE

SAFETY INSTRUCTIONS

- Always read the safety instructions carefully.
- Keep this User's Manual for future reference.
- Keep this equipment away from humidity.
- Lay this equipment on a reliable flat surface before setting it up.
- The openings on the enclosure are for air convection hence protects the equipment from overheating. Do not cover the openings.
- Make sure the voltage of the power source and adjust properly 110/220V before connecting the equipment to the power inlet.
- Place the power cord in such a way that people cannot step on it. Do not place anything over the power cord.
- Always unplug the power cord before inserting any add-on card or module.
- All cautions and warnings on the equipment should be noted.
- Never pour any liquid into the opening. Liquid can cause damage or electrical shock.
- If any of the following situations arises, get the equipment checked by a service personnel:
 - The power cord or plug is damaged.
 - Liquid has penetrated into the equipment.
 - The equipment has been exposed to moisture.
 - The equipment has not worked well or you cannot get it work according to User's Manual.
 - The equipment has dropped and damaged.
 - If the equipment has obvious sign of breakage.
- Do not leave this equipment in an environment unconditioned or in a storage temperature above 60°C (140°F). The equipment may be damaged.

**Caution:**

Only use the appropriate battery specified for this product.
Do not reuse, recharge, or reheat an old battery.
Do not attempt to force open the battery.
Do not discard used batteries with regular trash.
Discard used batteries according to local regulations.



BOX CONTENTS

- One EPIA-P700 Pico-ITX Mainboard
- One P700-A I/O Board
- One P700-B I/O Board
- One IDE Cable
- One SATA Cable
- One SATA Power Cable
- One DC-In Power Cable
- One Driver and Utilities CD

TABLE OF CONTENTS

Safety Instructions	iii
Box Contents	iv
Table of Contents	v
Chapter 1 Specifications	1
Mainboard Specifications	2
P700 Mainboard Layout	4
P700 I/O Boards Specification	5
P700-A I/O Board	5
COM (Serial) port	6
VGA port	6
RJ-45 LAN port	6
DVI-D pin header	6
P700-A board-to-board connector	6
P700-B I/O Board	7
USB 2.0 ports	8
Audio jacks: (Line-out, Line-in, Mic-in)	8
USB 2.0 pin header	8
PS/2 pin header	8
Front Panel pin header	8
LPC pin header	8
GPIO pin header	8
P700-B board-to-board connector	8
Chapter 2 Installation	9
CPU	10
CPU Fan	10
Memory Module Installation	11
Memory Slot: DDR2 SODIMM SDRAM	11
DDR2 SDRAM Module Installation Procedures	11
Available DDR2 SDRAM Configurations	12
Power Connectors	13
DC-In Power	13
External Battery	13
+5V SATA Power	13
Mainboard Pin Headers and Connectors	14
Ethernet LAN	14
DVI+CRT	14
Audio	14
PS/2	15
Front Panel: Case connector	15

LPC/SMBus/GPIO	15
COM (Serial).....	16
LVDS Panel.....	16
USB.....	16
IDE.....	17
SATA.....	17
Jumpers	18
Clear CMOS	18
LCD Power Selector: LCD 3V/5V	18
Mainboard Pin Header and Connector Vendor Lists.....	19
Mainboard and I/O Boards Installation Procedure.....	20
P700-A Board Pin Header and Connector.....	23
DVI-D pin header	23
P700-A Board to Board connector	24
P700-A Pin Header and Connector Vendor Lists.....	25
P700-B Board Pin Header and Connector.....	26
USB 2.0 pin header.....	26
PS/2 pin header	27
Front Panel pin header	27
LPC pin header.....	27
I ² C Bus (SMBus) pin header	28
GPIO pin header	28
P700-B Board to Board connector.....	29
P700-B Pin Header and Connector Vendor Lists.....	30
Chapter 3 BIOS Setup.....	31
Entering the BIOS Setup Menu	32
Control Keys	33
Navigating the BIOS Menus	34
Getting Help.....	35
Main Menu.....	36
Standard CMOS Features	36
Advanced BIOS Features.....	36
Advanced Chipset Features	36
Integrated Peripherals	36
Power Management Setup	36
PnP/PCI Configurations.....	36
Frequency/Voltage Control	37
Load Fail-Safe Defaults.....	37
Load Optimized Defaults.....	37
Set Supervisor Password.....	37
Set User Password.....	37
Save & Exit Setup.....	37
Exit Without Saving.....	37

Standard CMOS Features	38
Date	38
Time.....	38
Video.....	38
Halt On.....	38
IDE Drives	39
IDE Channel 0 Master.....	39
IDE Channel 0 Slave.....	39
IDE Channel 1 Master.....	40
IDE Channel 1 Slave.....	40
Advanced BIOS Features.....	42
Virus Warning.....	42
Quick Power On Self-Test	42
First/Second/Third Boot Device.....	43
Boot Other Device.....	43
Boot Up NumLock Status.....	43
Typematic Rate Setting.....	43
Typematic Rate (Chars/Sec).....	43
Typematic Delay (Msec).....	44
Security Option.....	44
MPS Version Control for OS.....	44
OS Select for DRAM > 64MB.....	44
Full Screen Logo Show	44
CPU Features.....	45
C7 CMPXCHG8.....	45
C7 NoExecute (NX).....	45
Hard Disk Boot Priority.....	46
Advanced Chipset Features	47
Memory Hole.....	47
System BIOS Cacheable	47
Video RAM Cacheable	47
Init Display First.....	47
Select Display Device	47
Panel Type.....	48
AGP & P2P Bridge Control.....	49
AGP Aperture Size.....	49
AGP3.0 Mode.....	49
AGP Driving Control	49
AGP Driving Value.....	49
AGP Fast Write	50
AGP Master 1 WS Write.....	50
AGP Master 1 WS Read.....	50
AGP 3.0 Calibration Cycle.....	50

VGA Share Memory Size.....	50
Direct Frame Buffer	50
CPU & PCI Bus Control	51
PCI Delay Transaction	51
DRDY Timing.....	51
Integrated Peripherals.....	52
UltraDMA66 Control.....	52
WatchDog Support	52
WatchDog Timer Select	52
WatchDog Count Value	52
Onboard Serial Port.....	52
VIA OnChip PCI Device	53
Azalia HDA Controller.....	53
USB Device Setting.....	54
USB 1.0 Controller.....	54
USB 2.0 Controller.....	54
USB Operation Mode.....	54
USB Keyboard Function	54
USB Storage Function.....	54
Power Management Setup	55
ACPI Suspend Type.....	55
Power Management Option.....	55
HDD Power Down.....	55
Suspend Mode.....	56
Video Off Option.....	56
Video Off Method.....	56
MODEM Use IRQ.....	56
Soft-Off by PWRBTN	56
Run VGABIOS if S3 Resume.....	56
AC Loss Auto Restart.....	56
Wakeup Event Detect.....	57
PS2KB Wakeup Select	57
PS2KB Wakeup Key Select	57
PS2MS Wakeup Key Select.....	57
PS2 Keyboard Power On.....	57
PS2 Mouse Power On	58
PowerOn by PCI Card.....	58
Modem Ring Resume	58
RTC Alarm Resume.....	58
Date (of Month).....	58
Resume Time (hh : mm : ss).....	58
PnP/PCI Configurations.....	59
PNP OS Installed	59

Reset Configuration Data	59
Resources Controlled By	60
PCI/VGA Palette Snoop	60
Assign IRQ for VGA	60
Assign IRQ for USB	60
Maximum ASPM supported	60
Maximum Payload Size	60
Frequency/Voltage Control	61
Auto Detect PCI Clk	61
Spread Spectrum	61
DRAM Clock/Drive Control	62
DRAM Clock	62
DRAM Timing	62
Read to Precharge (Trtp)	62
Write to Read CMD (Twtr)	62
Write Recovery Time (Twr)	62
DRAM Command Rate	63
RDSAIT mode	63
Load Fail-Safe Defaults	64
Load Optimized Defaults	65
Set Supervisor/User Password	66
Set Supervisor Password	66
User Password	66
Save & Exit Setup	68
Exit Without Saving	69
Chapter 4 Driver Installation	71
Driver Utilities	72
Getting Started	72
Running the Driver Utilities CD	73
CD Content	74

This page is intentionally left blank.

CHAPTER 1

SPECIFICATIONS

The ultra-compact and highly integrated VIA EPIA-P700 Pico-ITX mainboard is the smallest form-factor available today. Through a high level of integration, the Pico-ITX form factor is 75% smaller than Mini-ITX form factor. The mainboard enables the creation of an exciting new generation of small, ergonomic, innovative and affordable embedded systems. The mainboard comes with an integrated VIA C7[®] NanoBGA2 or fanless VIA Eden processor, boasting of ultra-low power consumption and cool operation.

Mainboard Specifications

CPU

- VIA C7 1.0 GHz NanoBGA2 processor
- VIA Eden ULV 500MHz NanoBGA2 processor

Chipset

- VIA VX700 advanced all-in-one system processor

Graphics

- Integrated VIA UniChrome™ Pro II 3D/2D AGP graphics with MPEG-2/4 and WMV9 video decoding acceleration

Memory

- One DDR2 667/533 SODIMM slot (up to 1 GB memory size)

IDE

- One UltraDMA 133/100 pin connector (2.0mm 44-pin right-angle type)

SATA

- One SATA connector
- One SATA power connector (5V)

LAN

- One VIA VT6122 Gigabit Ethernet Controller (default)
- One VIA VT6107 10/100 Mbps Fast Ethernet controller (manufacturing option)

Audio

- VIA VT1708B High Definition Audio Codec

Onboard I/O Connectors

- One LAN pin header
- One CRT/DVI pin header
- One COM (Serial) port pin header
- One CPU fan pin connector
- One Audio pin connector for Line-out, Line-in and Mic-in)
- One Front panel pin header
- Four USB2.0 ports pin header
- One PS2 mouse/keyboard pin header
- One LVDS pin connector (powered with 5V)
- One LPC/SMBus/GPIO pin header
- One +12V DC-in 2-pin jack with lock

System Monitor and Management

- Keyboard Power-on, Timer-Power-on
- System power management, AC power failure recovery
- Wake-On-LAN
- Watch Dog Timer

Operating Temperature

- 0°C up to 50°C

Operating Humidity

- 0% ~ 90% (relative humidity; non-condensing)

BIOS

- Award BIOS with LPC 4/8Mbit flash memory capacity

Form Factor

- Pico-ITX (10-layer)
- 10cm x 7.2cm

P700 Mainboard Layout

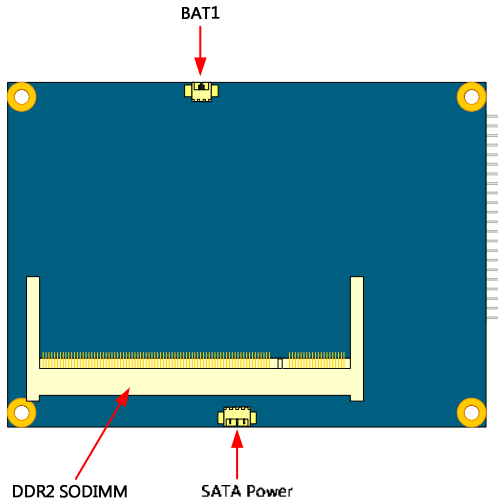
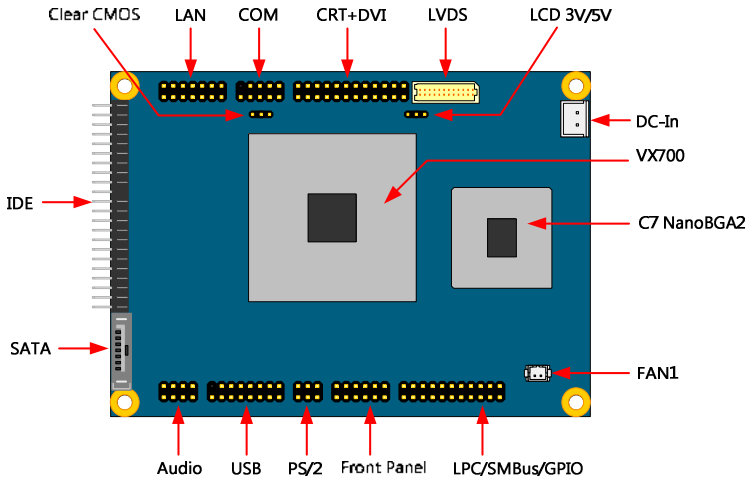

P700 I/O Boards Specification

The VIA EPIA-P700 Pico-ITX mainboard is bundled with two I/O boards (P700-A and P700-B) to support connections to LAN, VGA, COM, DVI-D, USB and Audio.

P700-A I/O Board

- One COM (Serial) port
- One VGA port
- One RJ-45 port
- One DVI-D pin header
- P700-A board-to-board connector

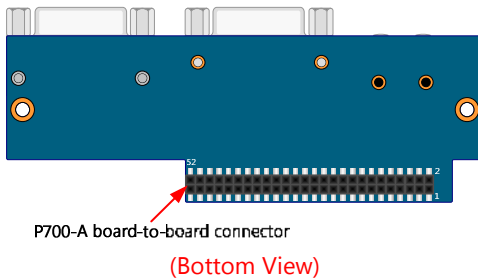
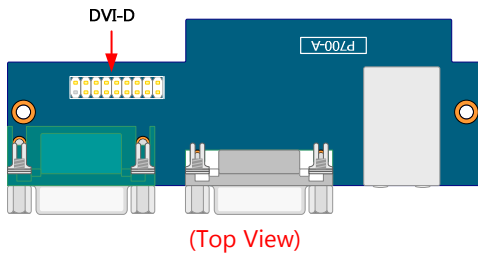
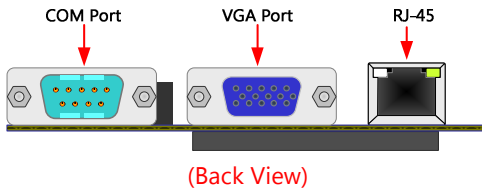

COM (Serial) port

The green 9-pin COM port is for pointing devices or other serial devices.

VGA port

The VGA port allows you to connect any analog VGA monitor.

RJ-45 LAN port

The board provides one Gigabit Ethernet port controlled by a VIA VT6122 Gigabit Ethernet controller. This port allows connection to a Local Area Network (LAN) through a network hub.

DVI-D pin header

The 18-pin header allows you to connect display with digital connection.

P700-A board-to-board connector

A 52-pin board connector used for mounting the P700-A I/O board to the EPIA-P700 mainboard.

P700-B I/O Board

- Four USB 2.0 ports
- Three audio jacks (Line-in, Line-out and Mic-in)
- USB 2.0 pin header
- PS/2 pin header
- Front Panel pin header
- LPC pin header
- I²C Bus (SMBus) pin header
- GPIO pin header
- P700-B board-to-board connector

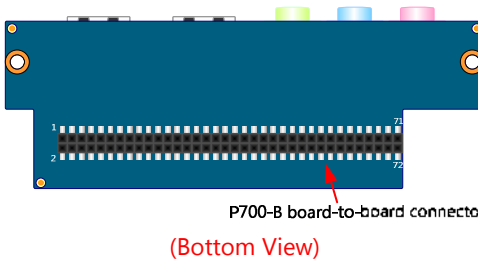
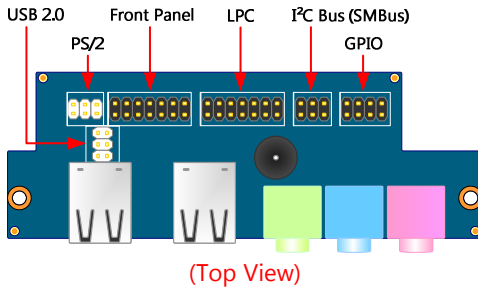
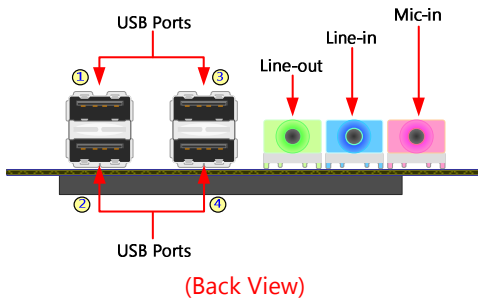

USB 2.0 ports

These four Universal Serial Bus (USB) ports are available for connecting USB 2.0 devices.

Audio jacks: (Line-out, Line-in, Mic-in)

The Line-out jack is for connecting to external speakers or headphones. The Line-in jack is for connecting to an external audio device such as a CD player, tape player, etc. The Mic-in jack is for connecting to a microphone.

Jack	2-channel	6-channel
Line-out	Line-out	Front (Left/Right)
Line-in	Line-in	Rear (Left/Right)
Mic-in	Microphone	Center/Sub-woofer

USB 2.0 pin header

Use to connect the USB module (e.g. WLAN USB).

PS/2 pin header

Use to attach a PS/2 port for the keyboard and mouse.

Front Panel pin header

Use to connect the power switch, reset switch, power LED, suspend LED, HDD LED and the case speaker.

LPC pin header

Use to connect the LPC devices.

GPIO pin header

General purpose input and output.

P700-B board-to-board connector

The 72-pin board connector used for mounting the P700-B I/O board to the EPIA-P700 mainboard.

CHAPTER 2

INSTALLATION

This chapter provides you with information about hardware installation procedures. It is recommended to use a grounded wrist strap before handling computer components. Electrostatic discharge (ESD) can damage some components.

CPU

The VIA EPIA-P700 Pico-ITX mainboard is packaged with a standard VIA C7[®] 1.0 GHz NanoBGA2. The VIA C7[®] 1.0 GHz processor requires a heatsink with fan to provide sufficient cooling.

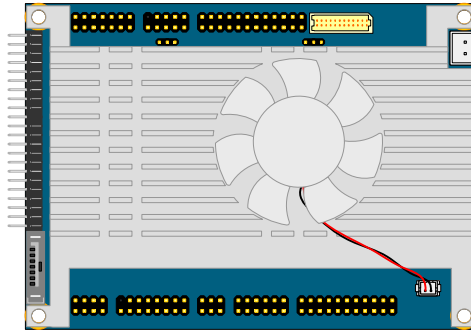

CPU Fan

The CPU fan runs on +5V and maintain CPU cooling. When connecting the wire to the connector, always be aware that the red wire (positive wire) should be connected to the +5V. The black wire is Ground and should always be connected to GND.

Pin	Signal
1	FAN_MCM
2	GND

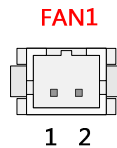

Memory Module Installation

Memory Slot: DDR2 SODIMM SDRAM

The VIA EPIA-P700 Pico-ITX mainboard provide one SODIMM slot for DDR2 667/533 MHz SDRAM memory modules and supports memory sizes up to 1GB.



Note:

DDR2 667 MHz memory modules can be used, but the effective speed will be 533 MHz.

DDR2 SDRAM Module Installation Procedures

Step 1

Locate the SODIMM slot in the mainboard.

Step 2

Align the notch on the SODIMM with the memory slot.

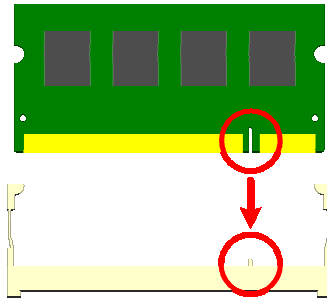

Step 3

Inset the SODIMM module at a 45 degree angle. Then push the SODIMM down until it snaps into the locking mechanism.

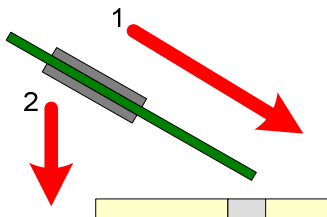

Available DDR2 SDRAM Configurations

Refer to the table below for available DDR2 SDRAM configurations on the mainboard.

Slot	Module Size	Total
SODIMM	64MB, 128MB, 256MB, 512MB, 1GB	64MB - 1GB
	Maximum supported system memory	64MB - 1GB

**Note:**

Only supports 1GB SDRAM with 64M x 8bits x16 configuration.

Power Connectors

When inserting the power supply connector, always make sure that all components are installed correctly to ensure that no damage will be caused.

DC-In Power

The mainboard supports a Pico-ITX 12V DC-In power supply for the power system. The 2-pin power connector used to connect the DC-in power jack for system power.

Pin	Signal
1	DC In
2	GND

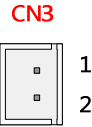

External Battery

The mainboard comes with external CMOS battery connector. This 2-pin connector used to connect the external cable battery for CMOS.

Pin	Signal
1	A3V (+3.3V)
2	GND

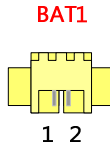

+5V SATA Power

The mainboard supports a 3-pin SATA power connector for SATA power cable. Plug the SATA power cable into the SATA power connector. Make sure the power plug is inserted in the proper orientation and pins are aligned.

Pin	Signal
1	+5V
2	+5V
3	GND

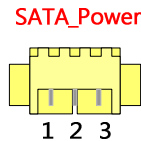

Mainboard Pin Headers and Connectors

Ethernet LAN

This pin header allows the connection to a Local Area Network.

Pin	Signal	Pin	Signal
1	A3V3GL (+3.3V)	2	A3V (+3.3V)
3	TXNC	4	TXND
5	TXPC	6	TXPD
7	TXNA	8	TXNB
9	TXPA	10	TXPB
11	GND	12	LED1
13	LED2	14	LINK ACT

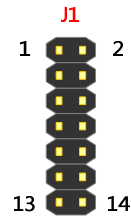

DVI+CRT

This pin header connects the interface to multi display devices and enables either digital or analog display.

Pin	Signal	Pin	Signal
1	RED	2	+5V
3	GREEN	4	GND
5	BLUE	6	CRT I2C Data
7	GND	8	CRT I2C Clock
9	GND	10	VS
11	TXC-	12	HS
13	TXC+	14	GND
15	TX0-	16	DVI I2C Data
17	TX0+	18	DVI I2C Clock
19	GND	20	GND
21	TX2-	22	TX1-
23	TX2+	24	TX1+

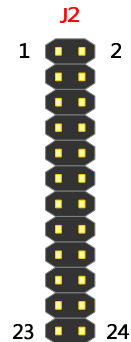

Audio

This is an interface for connections to external audio devices.

Pin	Signal	Pin	Signal
1	LINER	2	GND_AUD
3	LINEL	4	MIC IN L
5	LINEOUTR	6	MIC IN R
7	LINEOUTL	8	SENS A

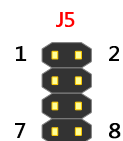

PS/2

The mainboard provides a PS/2 pin header to attach a PS2 port for the keyboard and mouse.

Pin	Signal	Pin	Signal
1	A5V	2	GND
3	KB_CLK	4	KB_DATA
5	MS_CLK	6	MS_DATA

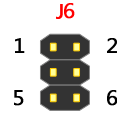

Front Panel: Case connector

The Front Panel pin header allows you to connect the power switch, reset switch, power LED, suspend LED, HDD LED and the case speaker.

Pin	Signal	Pin	Signal
1	PW_LED	2	+5V
3	PW_LED	4	HD_LED
5	GND	6	PW_BN
7	SPEAK_BZ	8	GND
9	GND	10	RST_SW
11	-	12	GND

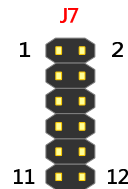

LPC/SMBus/GPIO

This single pin header allows the connection of LPC, SMBus devices and the General Purpose input and output.

Pin	Signal	Pin	Signal
1	GND	2	LAD3
3	SIO_OSC2	4	LAD2
5	PCLKLPC	6	LAD1
7	-LDRQ1	8	-LFRAME
9	SERIRQ	10	LAD0
11	-SIOSMI	12	-PCIRST1
13	+3V (+3.3V)	14	+5V
15	GPIO3	16	GPI14
17	GPIO2	18	GPI5
19	GND	20	SMBDT
21	GND	22	SMBCK

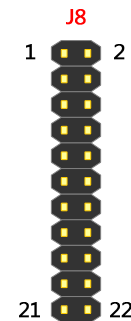

COM (Serial)

COM pin header can be used to attach an additional port for serial devices.

Pin	Signal	Pin	Signal
1	#DCDA	2	RXDA
3	TXDA	4	#DTRA
5	GND	6	#DSRA
7	#RTSA	8	#CTSA
9	#RIA	10	NC

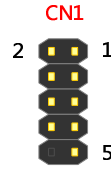

LVDS Panel

The single-channel LVDS connector allows you to connect the panel's LVDS cable directly to support LVDS panel.

Pin	Signal	Pin	Signal
1	LCD2D0-	2	LCD2D1-
3	LCD2D0+	4	LCD2D1+
5	GND	6	GND
7	PVDD2	8	LCD2D2-
9	PVDD2	10	LCD2D2+
11	LCD2_DATA	12	GND
13	LCD2_CLK	14	LCD2CLK+
15	GND	16	LCD2CLK-
17	VDD_BL	18	GND
19	VDD_BL	20	DIMMING
21	VDD_BL	22	BLEN2
23	GND	24	GND

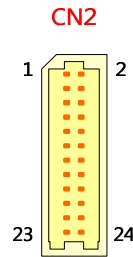

USB

The mainboard provide one 16-pin USB pin connector that allows up to four USB2.0 ports. These ports can be used to connect high-speed USB interface peripherals such as USB HDD, digital cameras, MP3 players, printers, modem, etc..

Pin	Signal	Pin	Signal
1	GND	2	NC
3	GND	4	GND
5	USB_VD3+	6	USB_VD2+
7	USB_VD-	8	USB_VD2-
9	+5V	10	+5V
11	USB_VD0-	12	USB_VD1-
13	USB_VD0+	14	USB_VD1+
15	GND	16	GND

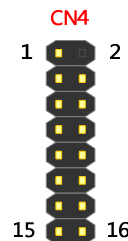

IDE

The mainboard has an Ultra DMA 133/100 controller. You can connect up to two IDE devices in any combination.

Pin	Signal	Pin	Signal
1	#IDERST	2	GND
3	PDD7	4	PDD8
5	PDD6	6	PDD9
7	PDD5	8	PDD10
9	PDD4	10	PDD11
11	PDD3	12	PDD12
13	PDD2	14	PDD13
15	PDD1	16	PDD14
17	PDD0	18	PDD15
19	GND	20	KEY
21	PDDREQ	22	GND
23	#PDIOW	24	GND
25	#PDIOR	26	GND
27	PIORDY	28	GND
29	#PDDACK	30	GND
31	IRQ15	32	NC
33	PDA1	34	GPI0
35	PDA0	36	PDA2
37	#PDCS1	38	#PDCS3
39	#HD_LED1	40	GND
41	+5V	42	+5V
43	GND	44	NC

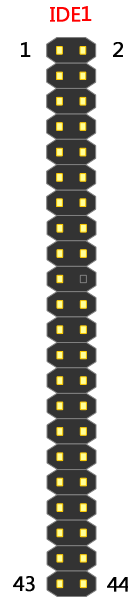

If two drives are connected to a single cable, the jumper on the second drive must be set to slave mode. Refer to the drive documentation supplied by the vendor for the jumper settings.

SATA

The next generation connector supports thin SATA cables for primary internal storage devices. The current SATA interface allows up to 300MB/s data transfer rate - faster than the standard parallel ATA with 133 MB/s (Ultra DMA).

SATA1



Jumpers

The mainboard provides jumpers for setting some mainboard functions. This section will explain how to change the settings of the mainboard functions using the jumpers.

Clear CMOS

The onboard CMOS RAM stores system configuration data and has an onboard battery power supply. To reset the CMOS settings, set the jumper on pins 1 and 2 while the system is off. Return the jumper to pins 2 and 3 afterwards. Setting the jumper while the system is on will damage the mainboard.

Setting	1	2	3
Normal Operation	ON	ON	OFF
Clear CMOS setting	OFF	ON	ON

J3

Normal 
1 2 3

Clear 
1 2 3



Caution:

Except when clearing the RTC RAM, never remove the cap on CLEAR_CMOS jumper default position. Removing the cap will cause system boot failure. Avoid clearing the CMOS while the system is on; it will damage the mainboard.

LCD Power Selector: LCD 3V/5V

This jumper determines the input voltage for the LCD connector.

Setting	1	2	3
+5V	ON	ON	OFF
+3V	OFF	ON	ON

J4

+5V 
1 2 3

+3V 
1 2 3

Mainboard Pin Header and Connector Vendor Lists

Items	Function	Pin	Pitch	Vendor	P/N
FAN1	CPU Fan	2 Pin	1.25mm	HRS	DF13C-2P-1.25V
CN5	DDRII SODIMM	200 Pin	0.6mm	Foxconn	AS0A426-N6RN-4F
CN3	DC-In Power	2 Pin	2.5mm	Neltron Industrial Co.	2317SJ-02
BAT1	External Battery	2 Pin	1.25mm	Neltron Industrial Co.	1251R-02-SM1-TR
SATA_Power	SATA Power	3 Pin	1.25mm	Neltron Industrial Co.	1251R-03-SM1-TR
J1	Ethernet LAN	14 Pin	2.0mm	Neltron Industrial Co.	2208SM-14G-BK-CP
J2	DVI+CRT	24 Pin	2.0mm	Neltron Industrial Co.	2208SM-24G-BK-CP
J5	Audio	8 Pin	2.0mm	Neltron Industrial Co.	2208SM-08G-BK-CP
J6	PS/2	6 Pin	2.0mm	Neltron Industrial Co.	2208SM-06G-BK-CP
J7	Front Panel	12 Pin	2.0mm	Neltron Industrial Co.	2208SM-12G-BK-CP
J8	LPC/SMBus/GPIO	22Pin	2.0mm	Neltron Industrial Co.	2208SM-22G-BK-CP
CN1	COM (Serial)	10 Pin	2.0mm	Neltron Industrial Co.	2208SM-10G-E9-BK-CP
CN2	LVDS Panel	24 Pin	1.0mm	ACES Electronics	87216-2416-06
CN4	USB	16 Pin	2.0mm	Neltron Industrial Co.	2208SM-16G-E2-BK-CP
IDE1	IDE	44 Pin	2.0mm	Neltron Industrial Co.	2204R-44G-E01
J3	Clear CMOS	3 Pin	1.27mm	Neltron Industrial Co.	2199SA-03G-301523
J4	LCD Power Select	3 Pin	1.27mm	Neltron Industrial Co.	2199SA-03G-301523

Mainboard and I/O Boards Installation Procedure

Step 1

Disconnect all attached LAN, COM, DVI+CRT, Audio, USB, PS2, Front Panel and LPC/SMBus/GPIO cables from EPIA-P700 mainboard pin headers show in red.

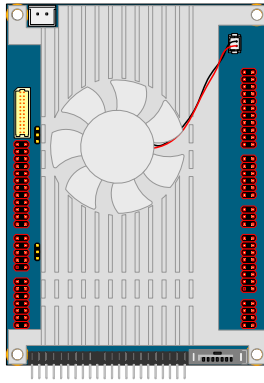

Step 2

Align and mounting the P700-A and P700-B I/O boards as shown in the diagram below.

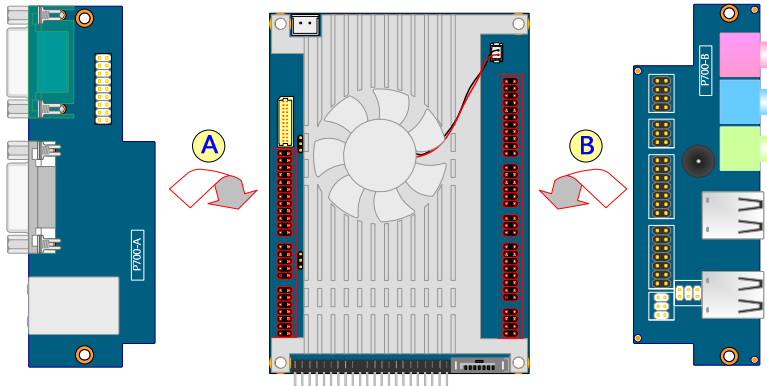

Step 3

First align the P700-A board-to-board connector of the P700-A I/O board with the J1, CN1 and J2 pin headers to the top side of the EPIA-P700 mainboard respectively. Then gently press down until the pins on the EPIA-P700 mainboard have been fully inserted into the board-to-board connector on the P700-A I/O board. (See the Step 5)

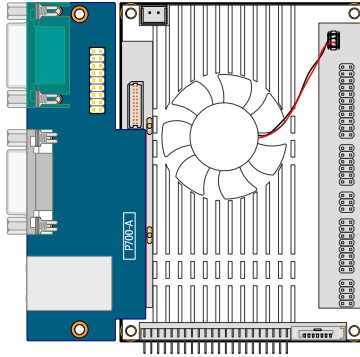

Step 4

Then align the P700-B board-to-board connector of the P700-B I/O board with the J5, CN4, J6, J7 and J8 pin headers to the top side of the EPIA-P700 mainboard respectively. Gently press down until the pins on the EPIA-P700 mainboard have been fully inserted into the board-to-board connector on the P700-B I/O board. (See the Step 5)

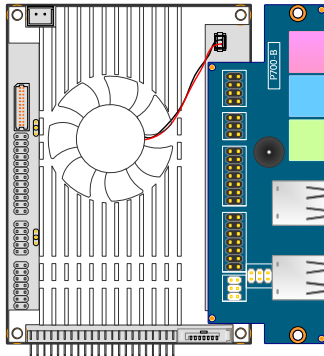

Step 5

Gently press down until the pins on the EPIA-P700 mainboard have been fully inserted into the board-to-board connectors of the I/O boards.

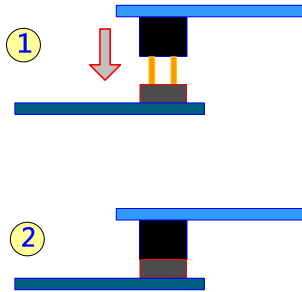

P700-A Board Pin Header and Connector

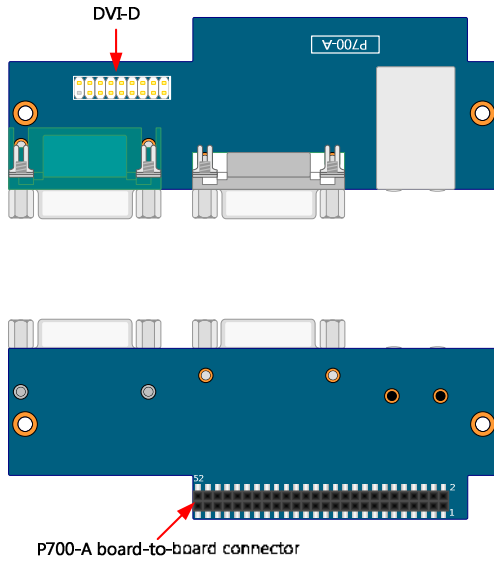

DVI-D pin header

This is an interface for connecting the DVI-D pin connector cable.

Pin	Signal	Pin	Signal
1	GND	2	+5V
3	TX2-	4	TX0+
5	TX2+	6	TX0-
7	GND	8	GND
9	TX1-	10	TXC+
11	TX1+	12	TXC-
13	GND	14	GND
15	SPD1	16	GND
17	SPCLK1	18	Key

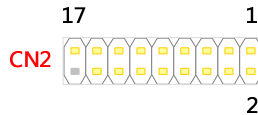

P700-A Board to Board connector

A 52-pin board connector used for mounting the P700-A I/O board to the EPIA-P700 mainboard.

Pin	Signal	Pin	Signal
1	A3V3GL(+3.3V)	2	A3V(+3.3V)
3	TXNC	4	TXND
5	TXPC	6	TXPD
7	TXNA	8	TXNB
9	TXPA	10	TXPB
11	GND	12	LED1
13	LED2	14	LNK ACT
15	-	16	-
17	GND	18	-
19	-DTRA	20	-RIA
21	TXDA	22	-CTSA
23	RXDA	24	-RTSA
25	-DCDA	26	-DSRA
27	-	28	-
29	RED	30	+5V
31	GREEN	32	GND
33	BLUE	34	SPD2
35	GND	36	SPCLK2
37	GND	38	VS
39	TXC-	40	HS
41	TCX+	42	GND
43	TX0-	44	SPD1
45	TX0+	46	SPCLK1
47	GND	48	GND
49	TX2-	50	TX1-
51	TX2+	52	TX1+



P700-A Pin Header and Connector Vendor Lists

Items	Function	Pin	Pitch	Vendor	P/N
J1	Board-to-Board	52 Pin	2.0mm	Neltron Industrial Co.	2207SM-52G-45-PCP
CN2	DVI-D	18 Pin	2.0mm	Neltron Industrial Co.	2316S-14G-F1

P700-B Board Pin Header and Connector

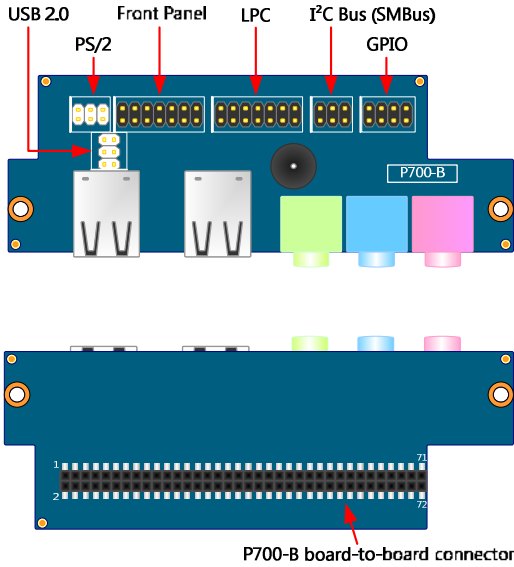

USB 2.0 pin header

The USB pin header allows you to attach USB module (e.g. WLAN USB).

Pin	Signal	Pin	Signal
1	USBCVD3+	2	USBCVD3-
3	USB_VD3+	4	USB_VD3-
5	VCC_USB2	6	GND

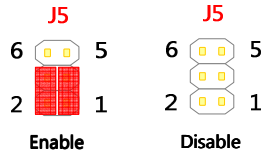

Setting	USB Port 3	USB Module
Enable (Default)	ON	OFF
Disable	OFF	ON



Note:
Removing the caps will disable the USB Port 3.

PS/2 pin header

The PS/2 pin header to attach a PS/2 port for the keyboard and mouse.

Pin	Signal	Pin	Signal
1	A5V (+5V)	2	GND
3	KB_CLK	4	KB_DATA
5	MS_CLK	6	MS_DATA

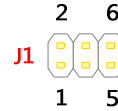

Front Panel pin header

The Front Panel pin header allows you to connect the power switch, reset switch, power LED, suspend LED, HDD LED and the case speaker.

Pin	Signal	Pin	Signal
1	PW_LED	2	HD_PW
3	PW_LED	4	HD_LED
5	SUS_LED	6	PW_BN
7	+5V	8	GND
9	GND	10	RST_SW
11	GPI5	12	GND
13	SPEAK_BZ	14	-

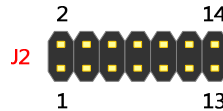

LPC pin header

This pin connector is for LPC devices.

Pin	Signal	Pin	Signal
1	+3V (+3.3V)	2	-PCIRST1
3	PCLKLPC	4	LAD0
5	-LFRAME	6	LAD1
7	LAD3	8	LAD2
9	GND	10	+5V
11	SIO_OSC2	12	SERIRQ
13	-LDRQ1	14	-SIOSMI

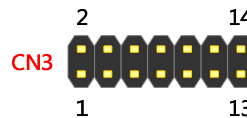

I²C Bus (SMBus) pin header

This pin header allows you to connect SMBus (System Management Bus) devices. Devices communicate with a SMBus host and/or other SMBus devices using the SMBus interface.

Pin	Signal	Pin	Signal
1	-	2	+5V
3	GND	4	+3V (+3.3V)
5	SMBDT	6	SMBCK

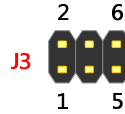

GPIO pin header

General purpose input and output.

Pin	Signal	Pin	Signal
1	+3V (+3.3V)	2	+5V
3	GPI4	4	GPIO3
5	GPI5	6	GPIO2
7	GND	8	GND

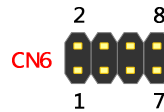

P700-B Board to Board connector

The 72-pin board connector used for mounting the P700-B I/O board to the EPIA-P700 mainboard.

Pin	Signal	Pin	Signal
1	LINER	2	GND_AUD
3	LINEL	4	MICIN
5	LINEOUTR	6	AD_5V
7	LINEOUTL	8	SENSEA
9	-	10	-
11	GND	12	-
13	GND	14	GND
15	USB VD3+	16	USB VD2
17	USB VD3-	18	USB VD2
19	+5V	20	+5V
21	USB VD0-	22	USB VD1-
23	USB VD0+	24	USB VD1+
25	GND	26	GND
27	-	28	-
29	A5V	30	GND
31	KB CLK	32	KB DATA
33	MS CLK	34	MS DATA
35	-	36	-
37	PW_LED	38	HD_PW
39	PW_LED	40	HD_LED
41	GND	42	PW_BN
43	SPEAK_BZ	44	GND
45	GND	46	RST_SW
47	SUS_LED	48	GND
49	-	50	-
51	GND	52	LAD3
53	SIO_OSC2	54	LAD2
55	PCLKLPC	56	LAD1
57	-LDRQ1	58	-LFRAME
59	SERIRQ	60	LAD0
61	-SIOSMI	62	-PCIRST1
63	+3V (+3.3V)	64	+5V
65	GPIO3	66	GPI14
67	GPIO2	68	GPI5
69	GND	70	SMBDT
71	GND	72	SMBCK

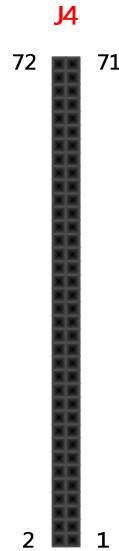

P700-B Pin Header and Connector Vendor Lists

Items	Function	Pin	Pitch	Vendor	P/N
J1	PS/2	6 Pin	2.0mm	Neltron Industrial Co.	2208SM-06G-CP
J2	Front Panel	14 Pin	2.54mm	Neltron Industrial Co.	2208SM-14G-CP

CHAPTER 3













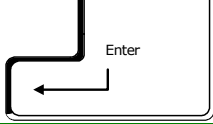

BIOS SETUP

This chapter gives a detailed explanation of the BIOS setup functions.

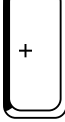
Entering the BIOS Setup Menu

Power on the computer and press <**Delete**> during the beginning of the boot sequence to enter the BIOS setup menu. If you missed the BIOS setup entry point, restart the system and try again.

Control Keys

Keys	Description
	Move to the previous item
	Move to the next item
	Move to the item in the left side
	Move to the item in the right side
	Select the item
	Jumps to the Exit menu or returns to the main menu from a submenu
	Increase the numeric value or make changes
	Decrease the numeric value or make changes
	Increase the numeric value or make changes
	Decrease the numeric value or make changes
	General help, only for Status Page Setup Menu and Option Page Setup Menu
	Restore the previous CMOS value from CMOS, only for Option Page Setup Menu
	Load the default CMOS value from Fail-Safe default table, only for Option Page Setup Menu
	Load Optimized defaults
	Save all the CMOS changes and exit

Navigating the BIOS Menus

The main menu displays all the BIOS setup categories. Use the <Left>/<Right> and <Up>/<Down> arrow keys to select any item or sub-menu. Descriptions of the selected/highlighted category are displayed at the bottom of the screen.

An arrow symbol next to a field indicates that a sub-menu is available (see figure below). Press <Enter> to display the sub-menu. To exit the sub-menu, press <Esc>.

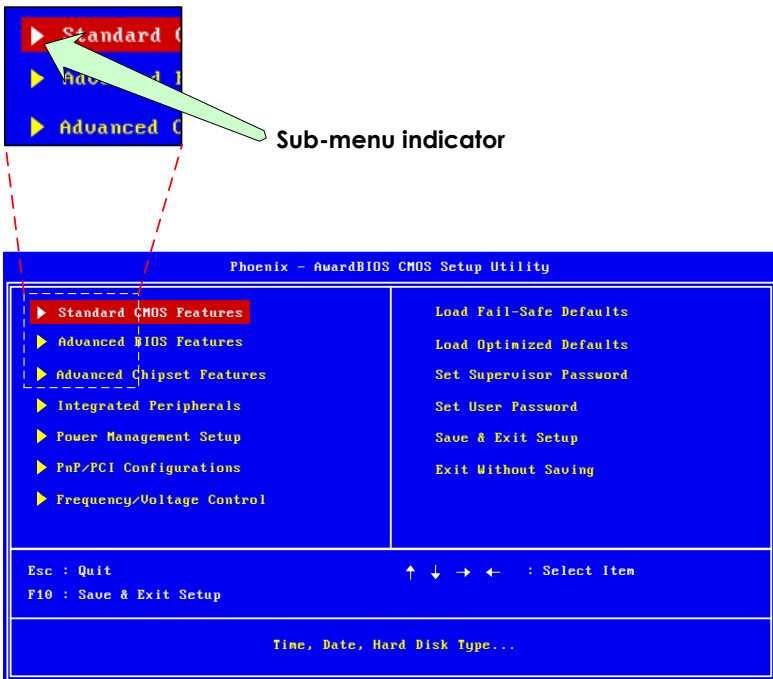

Getting Help

The BIOS setup program provides a "**General Help**" screen. You can display this screen from any menu/sub-menu by pressing <**F1**>. The help screen displays the keys for using and navigating the BIOS setup. Press <**Esc**> to exit the help screen.

Main Menu

The Main Menu contains eleven setup functions and two exit choices. Use arrow keys to select the items and press <Enter> to accept or enter Sub-menu.

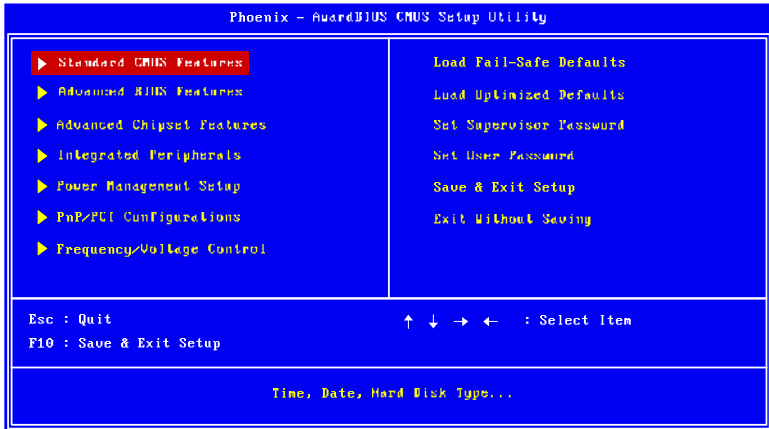

Standard CMOS Features

Use this menu to set basic system configurations.

Advanced BIOS Features

Use this menu to set the advanced features available on your system.

Advanced Chipset Features

Use this menu to set chipset specific features and optimize system performance.

Integrated Peripherals

Use this menu to set onboard peripherals features.

Power Management Setup

Use this menu to set onboard power management functions.

PnP/PCI Configurations

Use this menu to set the PnP and PCI configurations.

Frequency/Voltage Control

Use this menu to set the system frequency and voltage control.

Load Fail-Safe Defaults

Use this menu option to load the BIOS default settings for minimal and stable system operations.

Load Optimized Defaults

Use this menu option to load BIOS default settings for optimal and high performance system operations.

Set Supervisor Password

Use this menu option to set the BIOS supervisor password.

Set User Password

Use this menu option to set the BIOS user password.

Save & Exit Setup

Save BIOS setting changes and exit setup.

Exit Without Saving

Discard all BIOS setting changes and exit setup.

Standard CMOS Features

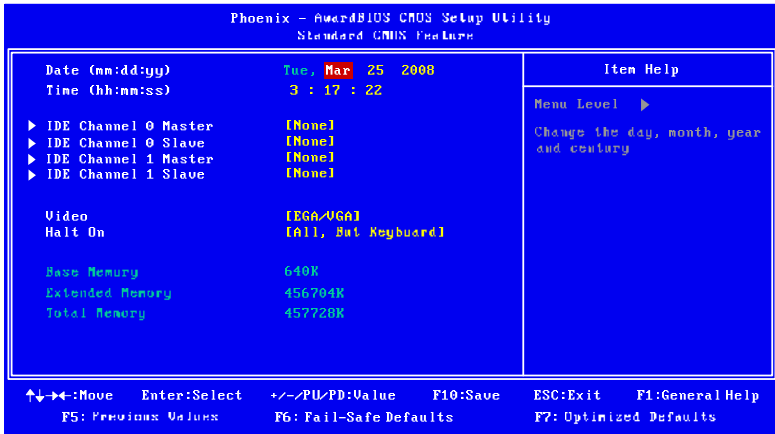

Date

The date format is [Day, Month Date, Year]

Time

The time format is [Hour : Minute : Second]

Video

Settings: [EGA/VGA, CGA 40, CGA 80, MONO]

Halt On

Set the system's response to specific boot errors. Below is a table that details the possible settings.

Settings	Description
All Errors	System halts when any error is detected
No Errors	System does not halt for any error
All, But Keyboard	System halts for all non-key errors

IDE Drives

IDE Channel 0 Master

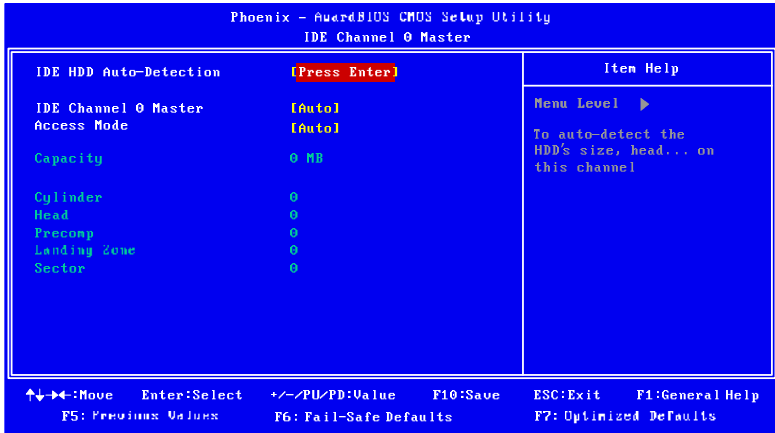

IDE Channel 0 Slave

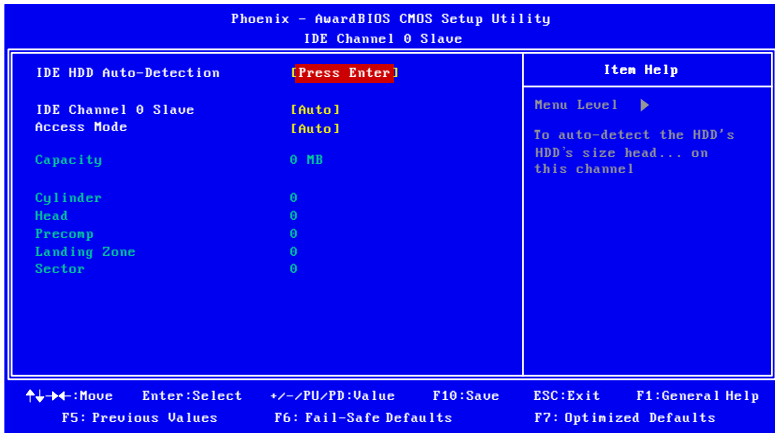

IDE Channel 1 Master

Phoenix - AwardBIOS CMOS Setup Utility		Item Help
IDE Channel 1 Master		
IDE HDD Auto-Detection	[Press Enter]	Menu Level ▶
IDE Channel 1 Master Access Mode	[Auto]	To auto-detect the HDD's size, head... on this channel
Capacity	0 MB	
Cylinder	0	
Head	0	
Precomp	0	
Landing Zone	0	
Sector	0	
Secondary Master PIO	[Auto]	
Secondary Master UDMA	[Auto]	

↑↓←→:Move Enter:Select +/-/PU/PD:Value F10:Save ESC:Exit F1:General Help
 F5: Previous Values F6: Fail-Safe Defaults F7: Optimized Defaults

IDE Channel 1 Slave

Phoenix - AwardBIOS CMOS Setup Utility		Item Help
IDE Channel 1 Slave		
IDE HDD Auto-Detection	[Press Enter]	Menu Level ▶
IDE Channel 1 Slave Access Mode	[Auto]	To auto-detect the HDD's size head... on this channel
Capacity	0 MB	
Cylinder	0	
Head	0	
Precomp	0	
Landing Zone	0	
Sector	0	
Secondary Slave PIO	[Auto]	
Secondary Slave UDMA	[Auto]	

↑↓←→:Move Enter:Select +/-/PU/PD:Value F10:Save ESC:Exit F1:General Help
 F5: Previous Values F6: Fail-Safe Defaults F7: Optimized Defaults

The specifications of your drive must match with the drive table. The hard disk will not work properly if you enter incorrect information in this category. Select **"Auto"** whenever possible. If you select **"Manual"**, make sure the information is from your hard disk vendor or system manufacturer.

Below is a table that details required hard drive information when using the **"Manual"** mode.

Settings	Description
IDE Channel	The name of this match the name of the menu. Settings: [None, Auto, Manual]
Access Mode	Settings: [CHS, LBA, Large, Auto]
Capacity	Formatted size of the storage device
Cylinder	Number of cylinders
Head	Number of heads
Precomp	Write precompensation
Landing Zone	Cylinder location of the landing zone
Sector	Number of sectors
Secondary Master PIO	Settings: [Auto, Mode 0, Mode 1, Mode 2, Mode 3, Mode 4]
Secondary Master UDMA	Settings: [Disabled, Auto]
Secondary Slave PIO	Settings: [Auto, Mode 0, Mode 1, Mode 2, Mode 3, Mode 4]
Secondary Slave UDMA	Settings: [Disabled, Auto]

Advanced BIOS Features

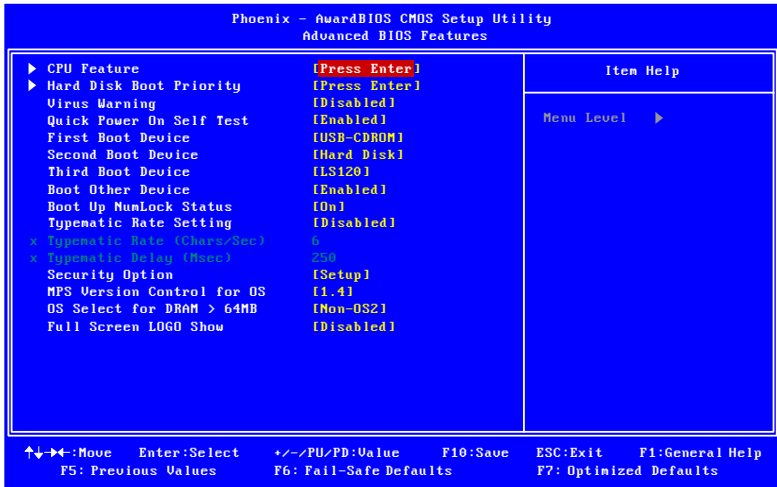

Virus Warning

Allows you to choose the VIRUS warning feature for IDE Hard Disk boot sector protection.

Settings	Description
Enabled	Turns on hard disk boot sector virus protection
Disabled	Turns off hard disk boot sector virus protection



Note:

If this function is enabled and someone attempt to write data into this area, BIOS will show a warning message on the screen.

Quick Power On Self-Test

Shortens Power On Self-Test (POST) cycle to enable shorter boot up time.

Settings	Description
Disabled	Standard Power On Self Test (POST)
Enabled	Shorten Power On Self Test (POST) cycle and boot up time

First/Second/Third Boot Device

Set the boot device sequence as BIOS attempts to load the disk operating system.

Settings	Description
LS120	Boot from LS-120 drive
Hard Disk	Boot from the HDD
CDROM	Boot from CDROM
ZIP100	Boot from ATAPI ZIP drive
USB-FDD	Boot from USB floppy drive
USB-ZIP	Boot from USB ZIP drive
USB-CDROM	Boot from USB CDROM
Legacy LAN	Boot from network drive
VIA Networking	Boot from network drive
Disabled	Disable the boot device sequence

Boot Other Device

Enables the system to boot from alternate devices if the system fails to boot from the "First/Second/Third Boot Device" lists.

Settings	Description
Disabled	No alternate boot device allowed
Enabled	Enable alternate boot device

Boot Up NumLock Status

Set the NumLock status when the system is powered on.

Settings	Description
Off	Forces keypad to behave as arrow keys
On	Forces keypad to behave as 10-key

Typematic Rate Setting

Enables "Typematic Rate" and "Typematic Delay" functions.

Settings: [Disabled, Enabled]

Typematic Rate (Chars/Sec)

This item sets the rate (characters/second) at which the system retrieves a signal from a depressed key.

Settings: [6, 8, 10, 12, 15, 20, 24, 30]

Typematic Delay (Msec)

This item sets the delay between, when the key was first pressed and when the system begins to repeat the signal from the depressed key.

Settings: [250, 500, 750, 1000]

Security Option

Selects whether the password is required every time the System boots, or only when you enter Setup.

Settings	Description
Setup	Password prompting appears only when end users try to run BIOS Setup
System	Password prompt appears every time when the computer is powered on and when end users try to run BIOS Setup

MPS Version Control for OS

Settings: [1.1, 1.4]

OS Select for DRAM > 64MB

Select OS2 only if you are running OS/2 operating system with greater than 64MB of RAM on the system.

Settings: [Non-OS2, OS2]

Full Screen Logo Show

Show full screen logo during BIOS boot up process.

Settings: [Disabled, Enabled]

CPU Features

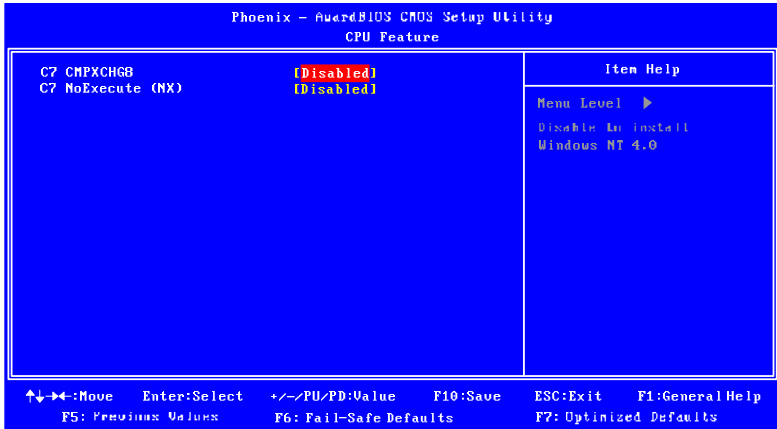

C7 CMPXCHG8

Disable to install Windows NT 4.0.

Settings: [Disabled, Enabled]

C7 NoExecute (NX)

NoExecute is supported in WinXP SP2 and provides some protection from virii.

Settings: [Disabled, Enabled]

Hard Disk Boot Priority

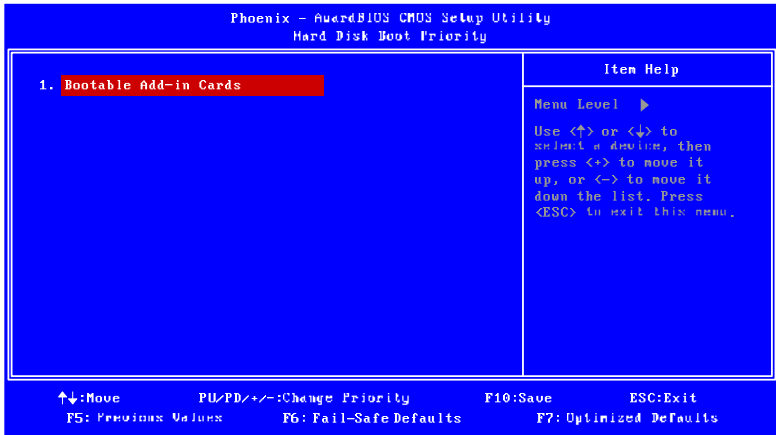

This is for setting the priority of the hard disk boot order when the "Hard Disk" option is selected in the "[First/Second/Third] Boot Device" menu item.

Advanced Chipset Features

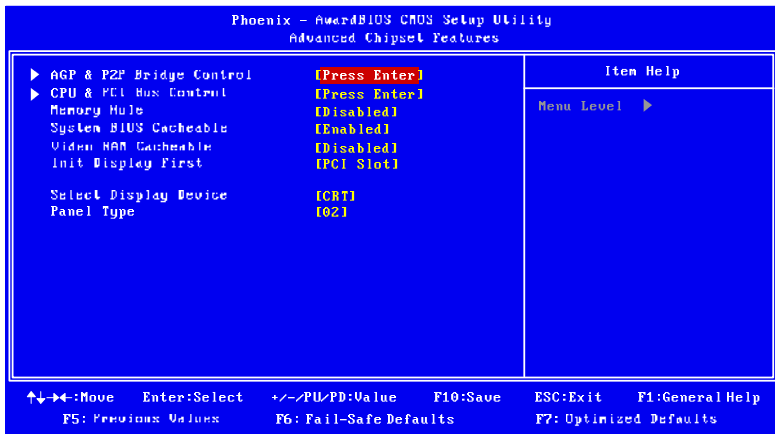

Caution:

The Advanced Chipset Features menu is used for optimizing the chipset functions. Do not change these settings unless you are familiar with the chipset.

Memory Hole

Settings: [Disabled, 15M – 16M]

System BIOS Cacheable

Settings: [Disabled, Enabled]

Video RAM Cacheable

Settings: [Disabled, Enabled]

Init Display First

Settings: [PCI Slot, AGP]

Select Display Device

This setting refers to the type of display being used with the system.

Settings: [CRT, LCD, CRT+LCD, DVI, LCD+DVI]

Panel Type

This setting refers to the native resolution of the display being used with the system.

Key in a HEX number.

Settings: [Min = 0000, Max = 000F]

AGP & P2P Bridge Control

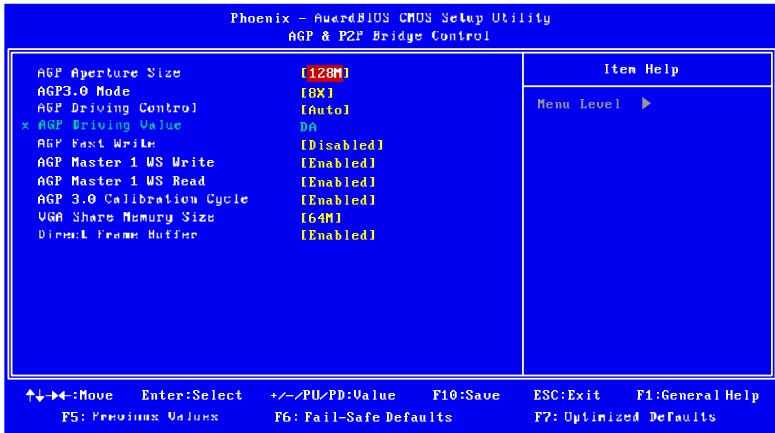

AGP Aperture Size

This setting controls how much memory space can be allocated to AGP for video purposes. The aperture is a portion of the PCI memory address range dedicated to graphics memory address space. Host cycles that hit the aperture range are forwarded to the AGP without any translation.

Settings: [32MB, 64MB, 128MB, 256MB, 512MB, 1GB]

AGP3.0 Mode

This mainboard supports the AGP 8x interface. When the AGP 8x video card is used, it can transfer video data at 2133MB/s. AGP 8x is backward compatible, leave the default 8x mode on. AGP 4x mode can be detected automatically once you plug in the AGP 4x card.

Settings: [8x, 4x]

AGP Driving Control

This item is used to signal driving current on AGP cards to auto or manual.

Settings: [Auto, Manual]

AGP Driving Value

Key in a HEX number.

Settings: [Min = 0000, Max = 00FF]

AGP Fast Write

This item is used to enable or disable the caching of display data for the video memory of the processor.

Settings: [Disabled, Enabled]

AGP Master 1 WS Write

Settings: [Disabled, Enabled]

AGP Master 1 WS Read

Settings: [Disabled, Enabled]

AGP 3.0 Calibration Cycle

Settings: [Disabled, Enabled]

VGA Share Memory Size

This setting allows you to select the amount of system memory that is allocated to the integrated graphics processor.

Settings: [Disabled, 32M, 64M, 128M]

Direct Frame Buffer

Settings: [Disabled, Enabled]

CPU & PCI Bus Control

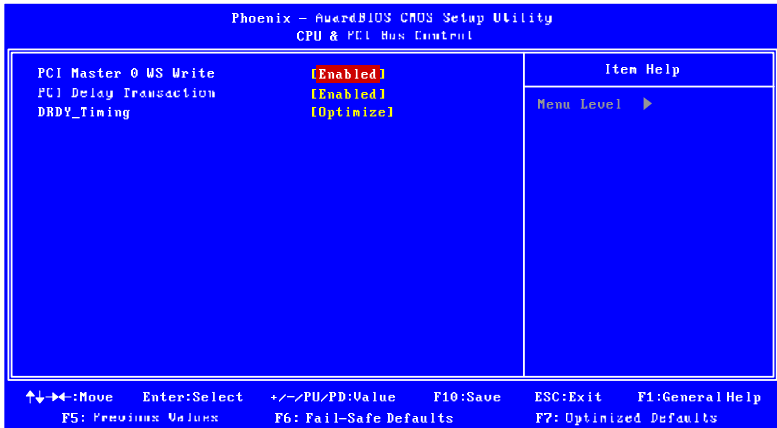

PCI Master 0 WS Write

Settings: [Enabled, Disabled]

PCI Delay Transaction

Settings: [Disabled, Enabled]

DRDY Timing

Settings: [Slowest, Default, Optimize]

Integrated Peripherals

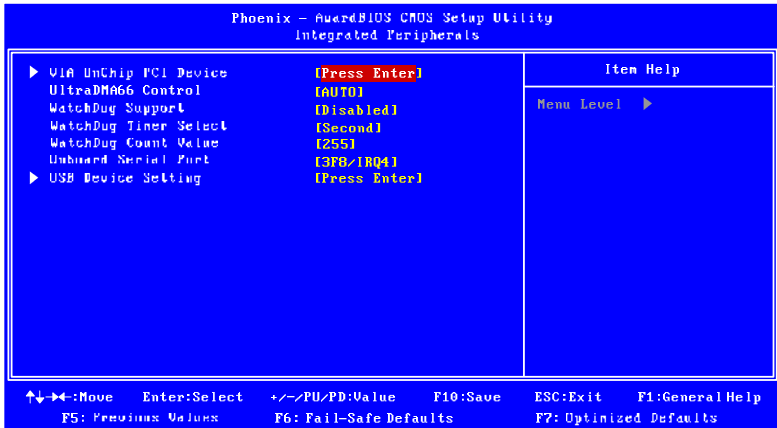

UltraDMA66 Control

Settings: [UltraDMA66, AUTO]

WatchDog Support

Settings: [Enabled, Disabled]

WatchDog Timer Select

Settings: [Minute, Second]

WatchDog Count Value

Key in a DEC number.

Settings: [Min = 0, Max = 255]

Onboard Serial Port

Settings: [Disabled, 3F8/IRQ4, 2F8/IRQ3, 3E8/IRQ4, 2E8/IRQ3, Auto]

VIA OnChip PCI Device

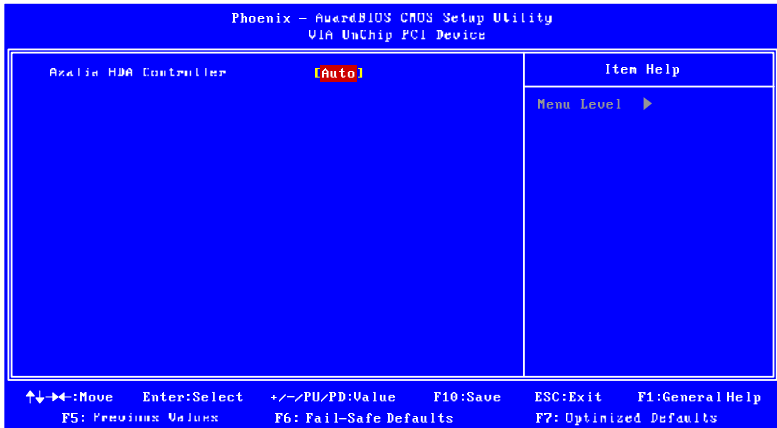

Azalia HDA Controller

Settings: [Auto, Disabled]

USB Device Setting

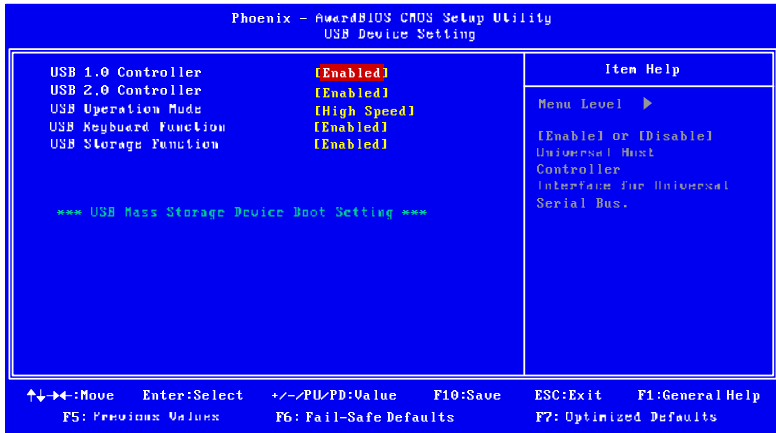

USB 1.0 Controller

Enable or disable Universal Host Controller Interface for Universal Serial Bus.

Settings: [Disabled, Enabled]

USB 2.0 Controller

Enable or disable Enhanced Host Controller Interface for Universal Serial Bus.

Settings: [Disabled, Enabled]

USB Operation Mode

Auto decide USB device operation mode.

Settings	Description
Full/Low Speed	All of USB Device operated on full/low speed mode
High Speed	If USB device was high speed device, then it operated on high speed mode.

USB Keyboard Function

Enable or disable Legacy support of USB Keyboard.

Settings: [Disabled, Enabled]

USB Storage Function

Enable or disable Legacy support of USB Mass Storage.

Settings: [Disabled, Enabled]

Power Management Setup

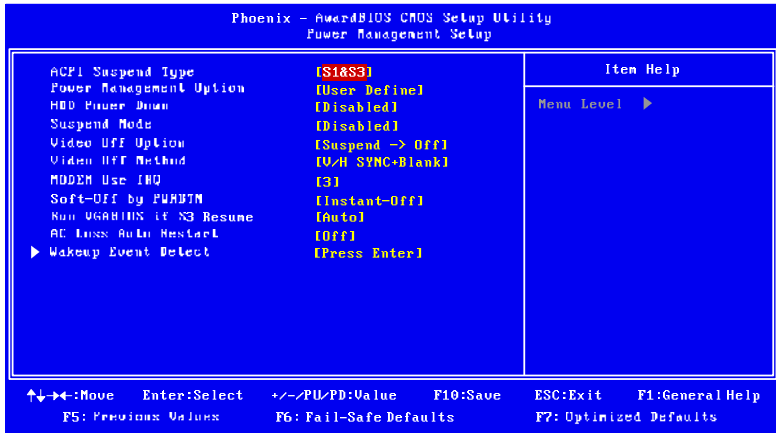

ACPI Suspend Type

Settings	Description
S1(POS)	S1/Power On Suspend (POS) is a low power state. In this state, no system context (CPU or chipset) is lost and hardware maintains all system contexts.
S3(STR)	S3/Suspend To RAM (STR) is a power-down state. In this state, power is supplied only to essential components such as main memory and wakeup-capable devices. The system context is saved to main memory, and context is restored from the memory when a "wakeup" event occurs.
S1 & S3	Depends on the OS to select S1 or S3.

Power Management Option

Settings: [User Define, Min Saving, Max Saving]

HDD Power Down

Set the length of time for a period of inactivity before powering down the hard disk.

Settings: [Disable, 1 Min, 2 Min, 3 Min, 4 Min, 5 Min, 6 Min, 7 Min, 8 Min, 9 Min, 10 Min, 11 Min, 12 Min, 13 Min, 14 Min, 15 Min]

Suspend Mode

Sets the length of time for a period of inactivity before entering suspend mode.

Settings: [Disable, 1 Min, 2 Min, 4 Min, 6 Min, 8 Min, 10 Min, 20 Min, 30 Min, 40 Min, 1 Hour]

Video Off Option

Select whether or not to turn off the screen when system enters power saving mode, ACPI OS such as Windows XP will override this option.

Settings	Description
Always On	Screen is always on even when system enters power saving mode
Suspend -> Off	Screen is turned off when system enters power saving mode

Video Off Method

Settings: [Blank Screen, V/H SYNC+Blank, DPMS Support]

MODEM Use IRQ

Settings: [NA, 3, 4, 5, 7, 9, 10, 11]

Soft-Off by PWRBTN

This field configures the power button on the chassis.

Settings	Description
Delay 4 Sec	System is turned off if power button is pressed for more than four seconds.
Instant-Off	Power button functions as a normal power-on/-off button.

Run VGABIOS if S3 Resume

Select whether to run VGA BIOS if resuming from S3 state. This is only necessary for older VGA drivers.

Settings: [Auto, Yes, No]

AC Loss Auto Restart

The field defines how the system will respond after an AC power loss during system operation.

Settings	Description
Off	Keeps the system in an off state until the power button is pressed
On	Restarts the system when the power is back
Former-Sts	Former-Sts

WakeUp Event Detect

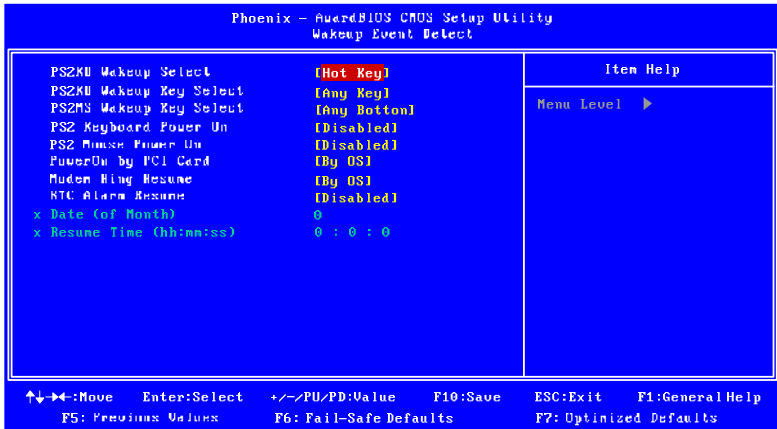

PS2KB Wakeup Select

When selecting Password, press Enter to change password. The maximum number of characters is eight.

Settings: [Hot Key, Password]

PS2KB Wakeup Key Select

Sets a Hot Key to restore the system from the power saving mode to an active state.

Settings: [Ctrl+F1, Ctrl+F2, Ctrl+F3, Ctrl+F4, Ctrl+F5, Ctrl+F6, Ctrl+F7, Ctrl+F8, Ctrl+F9, Ctrl+F10, Ctrl+F11, Ctrl+F12, Power, Wake, Any Key]

PS2MS Wakeup Key Select

Enables any mouse activity to restore the system from the power saving mode to an active state.

Settings: [Any Button, Left Button, Right Button]

PS2 Keyboard Power On

Settings: [Disabled, Enabled]

PS2 Mouse Power On

Settings: [Disabled, Enabled]

PowerOn by PCI Card

Enables activity detected from any PCI card to power up the system or resume from a suspended state. Such PCI cards include LAN, onboard USB ports, etc.

Settings: [By OS, Enabled]

Modem Ring Resume

Settings: [By OS, Enabled]

RTC Alarm Resume

Set a scheduled time and/or date to automatically power on the system.

Settings: [Disabled, Enabled]

Date (of Month)

The field specifies the date for "RTC Alarm Resume".

Resume Time (hh : mm : ss)

The field specifies the time for "RTC Alarm Resume".

PnP/PCI Configurations

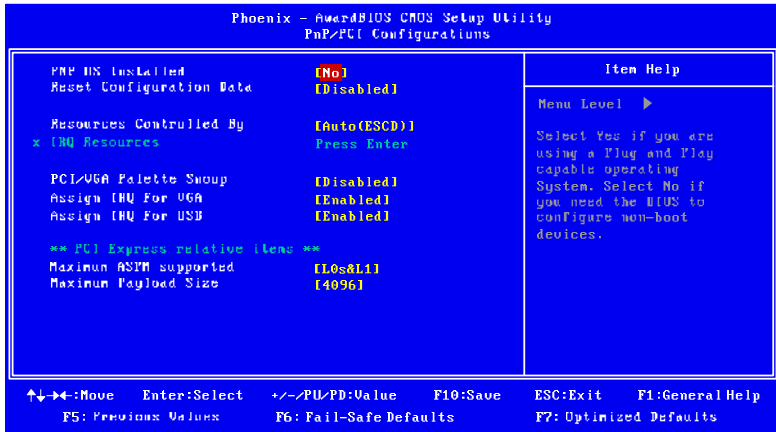

Note:

This section covers some very technical items and it is strongly recommended to leave the default settings as is unless you are an experienced user.

PNP OS Installed

Settings	Description
No	BIOS will initialize all the PnP cards
Yes	BIOS will only initialize the PnP cards used for booting (VGA, IDE, SCSI). The rest of the cards will be initialized by the PnP operating system.

Reset Configuration Data

This field should usually be left "Disabled"

Settings	Description
Disabled	Default setting
Enabled	Resets the ESCD (Extended System Configuration Data) after exiting BIOS Setup if a newly installed PCI card or the system configuration prevents the operating system from loading.

Resources Controlled By

Enable the BIOS to automatically configure all the Plug-and-Play compatible devices.

Settings	Description
Auto(ESCD)	BIOS will automatically assign IRQ, DMA and memory base address fields.
Manual	Unlocks "IRQ Resources" for manual configuration.

PCI/VGA Palette Snoop

Settings: [Disabled, Enabled]

Assign IRQ for VGA

Assign IRQ for VGA devices.

Settings: [Disabled, Enabled]

Assign IRQ for USB

Assign IRQ for USB devices.

Settings: [Disabled, Enabled]

Maximum ASPM supported

Control maximum level of ASPM supported on the given PCI Express links on the system.

Settings: [L0, L0s, L1, L0s&L1]

Maximum Payload Size

Set maximum TLP payload size for the PCI Express devices. The unit is byte.

Settings: [128, 256, 512, 1024, 2048, 4096]

Frequency/Voltage Control

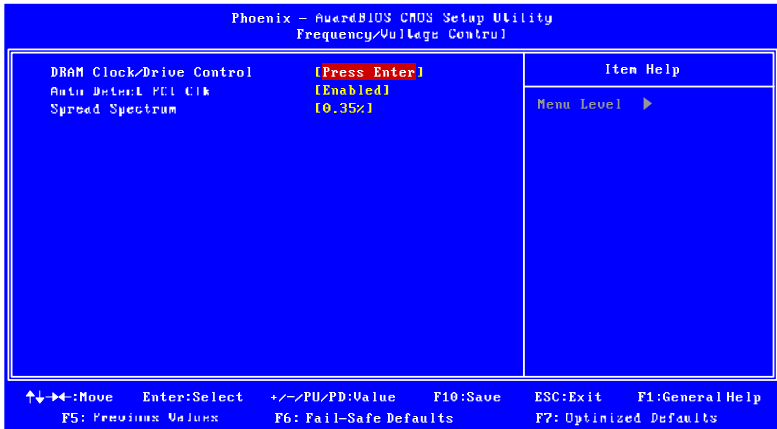

Auto Detect PCI Clk

Settings: [Enabled, Disabled]

Spread Spectrum

When the mainboard's clock generator pulses, the extreme values (spikes) of the pulses create EMI (Electromagnetic Interference). The Spread Spectrum function reduces the EMI generated by modulating the pulses so that the spikes of the pulses are reduced to flatter curves.

Settings: [Disabled, 0.35%]

DRAM Clock/Drive Control

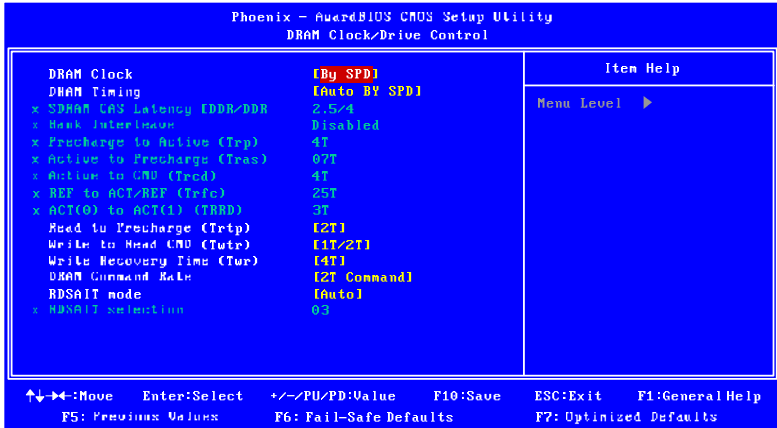

DRAM Clock

The chipset supports synchronous and asynchronous mode between host clock and DRAM clock frequency.

Settings: [By SPD, 200MHz, 266MHz]

DRAM Timing

The value in this field depends on the memory modules installed in your system. Changing the value from the factory setting is not recommended unless you install new memory that has different performance rating than the original modules.

Settings: [Manual, Auto By SPD]

Read to Precharge (Trtp)

Settings: [2T, 3T]

Write to Read CMD (Twtr)

Settings: [1T/2T, 2T/3T]

Write Recovery Time (Twr)

Settings: [2T, 3T, 4T, 5T]

DRAM Command Rate

Settings: [2T Command, 1T Command]

RDSAIT mode

Settings: [Manual Auto]

Load Fail-Safe Defaults

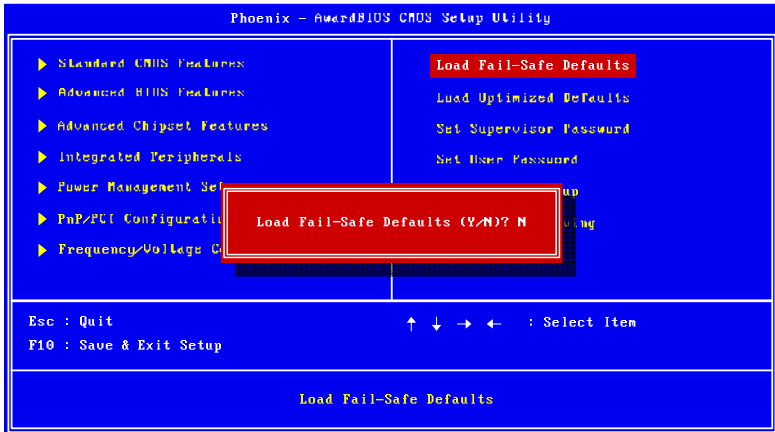

This option is for restoring all the default fail-safe BIOS settings. These values are set by the mainboard manufacturer to provide a stable system with basic performance.

Entering "Y" and press <Enter> to load the default fail-safe BIOS values. Entering "N" and press <Enter> will cancel the load fail-safe defaults request.

Load Optimized Defaults

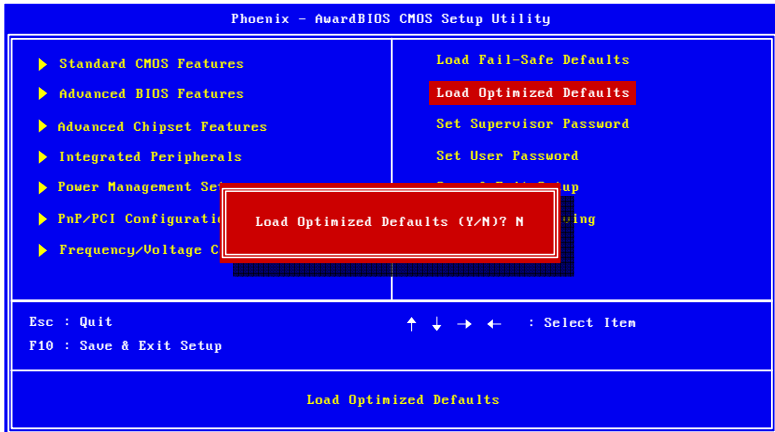

This option is for restoring all the default optimized BIOS settings. The default optimized values are set by the mainboard manufacturer to provide a stable system with optimized performance.

Entering "Y" and press <Enter> to load the default optimized BIOS values. Entering "N" and press <Enter> will cancel the load optimized defaults request.

Set Supervisor/User Password

Set Supervisor Password

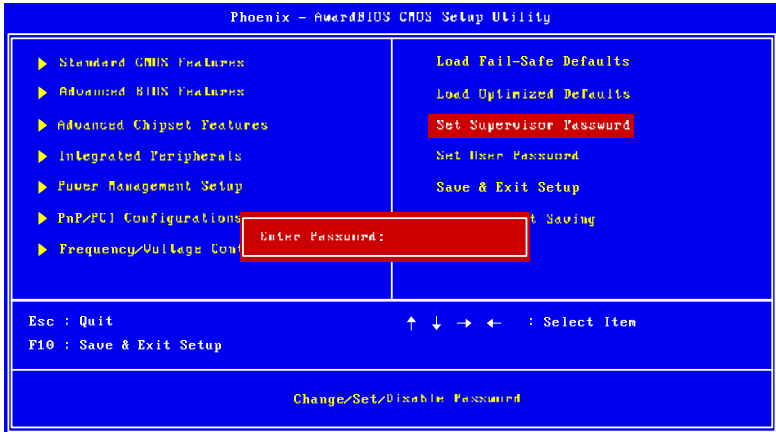

User Password

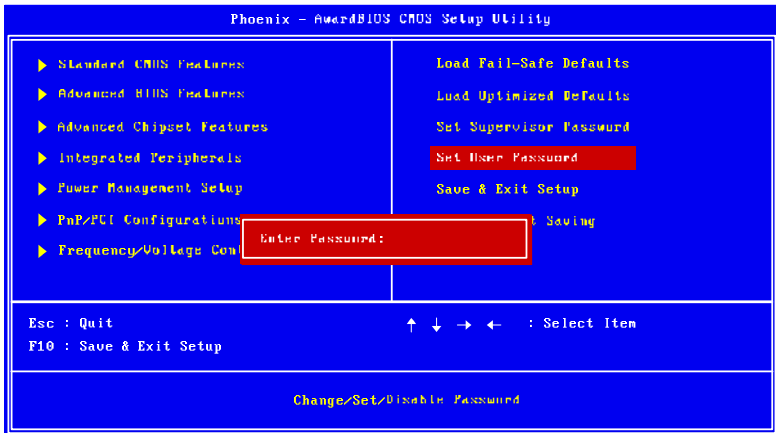

This option is for setting a password for entering BIOS Setup. When a password has been set, a password prompt will be displayed whenever BIOS Setup is run. This prevents an unauthorized person from changing any part of your system configuration.

There are two types of passwords you can set. A supervisor password and a user password. When a supervisor password is used, the BIOS Setup program can be accessed and the BIOS settings can be changed. When a user password is used, the BIOS Setup program can be accessed but the BIOS settings cannot be changed.

To set the password, type the password (up to eight characters in length) and press <Enter>. The password typed now will clear any previously set password from CMOS memory. The new password will need to be reentered to be confirmed. To cancel the process press <Esc>.

To disable the password, press <Enter> when prompted to enter a new password. A message will show up to confirm disabling the password. To cancel the process press <Esc>.

Additionally, when a password is enabled, the BIOS can be set to request the password each time the system is booted. This would prevent unauthorized use of the system. See "Security Option" in the "Advanced BIOS Features" section for more details.

Save & Exit Setup

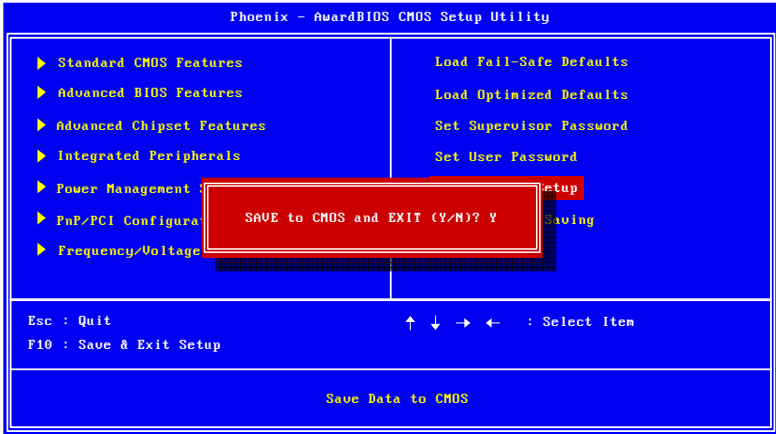

Entering "Y" saves any changes made, and exits the program.

Entering "N" will cancel the exit request.

Exit Without Saving

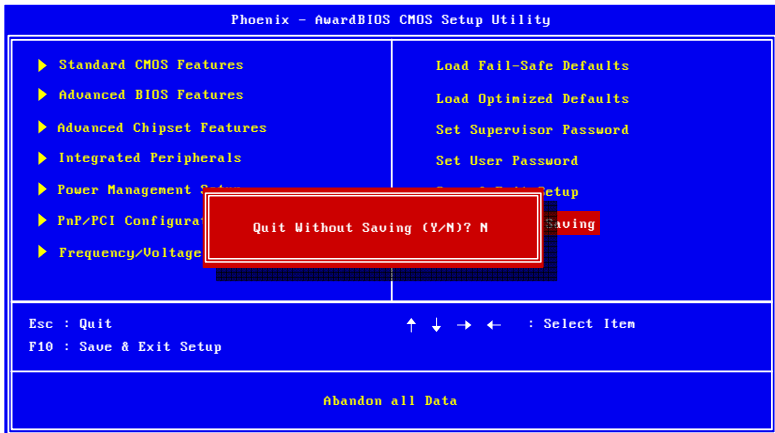

Entering "Y" discards any changes made and exits the program.

Entering "N" will cancel the exit request.

This page is intentionally left blank.

CHAPTER 4

DRIVER INSTALLATION

This chapter gives you brief descriptions of each mainboard driver and application. You must install the VIA chipset drivers first before installing other drivers such as VGA drivers. The applications will only function correctly if the necessary drivers are already installed.

Driver Utilities

Getting Started

VIA EPIA-P700 Developer kits include a Driver CD that contains the drivers and software for enhancing the performance of the mainboard. Regular kits do not include a Driver CD. However, the latest drivers can be downloaded from <http://www.viaembedded.com/>



Note:

The driver utilities and software are updated from time to time. The latest updated versions are available at <http://www.viaembedded.com/>

Running the Driver Utilities CD

To start using the CD, insert the CD into the CD-ROM or DVD-ROM drive. The CD should run automatically after closing the CD-ROM or DVD-ROM drive. The driver utilities and software menu screen should then appear on the screen. If the CD does not run automatically, click on the "Start" button and select "Run..." Then type: "D:\Setup.exe".

For Linux drivers, click the right button on mouse and click open. Linux drivers are located in the "Driver" folder.



Note:

D: might not be the drive letter of the CD-ROM/DVD-ROM in your system.

CD Content

- **VIA 4in1 Drivers:**
 - Contains VIA ATAPI Vendor Support Driver (enables the performance enhancing bus mastering functions on ATA-capable Hard Disk Drives and ensures IDE device compatibility), AGP VxD Driver (provides service routines to your VGA driver and interface directly to hardware, providing fast graphical access), IRQ Routing Miniport Driver (sets the system's PCI IRQ routing sequence) and VIA INF Driver (enables the VIA Power Management function).
 - Includes V-RAID and RAID tools.
- **VIA Graphics Driver:**
 - Enhances the onboard VIA graphic chip.
- **VIA Audio Driver:**
 - Enhances the onboard VIA audio chip.
- **VIA USB 2.0 Driver:**
 - Enhances VIA USB 2.0 ports.
- **VIA LAN Driver:**
 - Enhances the onboard VIA 10/100M LAN chip.
- **VIA RAID Driver**
 - Support for SATA RAID devices.