

User's Manual

EPIA-PE

Version 1.1
April 18, 2007

Copyright

Copyright © 2003-2007 VIA Technologies Incorporated. All rights reserved.

No part of this document may be reproduced, transmitted, transcribed, stored in a retrieval system, or translated into any language, in any form or by any means, electronic, mechanical, magnetic, optical, chemical, manual or otherwise without the prior written permission of VIA Technologies, Incorporated.

Trademarks

All trademarks are the property of their respective holders. PS/2 is a registered trademark of IBM Corporation. Award BIOS is a registered trademark of Phoenix Technologies Ltd.

Disclaimer

No license is granted, implied or otherwise, under any patent or patent rights of VIA Technologies. VIA Technologies makes no warranties, implied or otherwise, in regard to this document and to the products described in this document. The information provided in this document is believed to be accurate and reliable as of the publication date of this document. However, VIA Technologies assumes no responsibility for the use or misuse of the information in this document and for any patent infringements that may arise from the use of this document. The information and product specifications within this document are subject to change at any time, without notice and without obligation to notify any person of such change.

FCC-B Radio Frequency Interference Statement

This equipment has been tested and found to comply with the limits for a class B digital device, pursuant to part 15 of the FCC rules. These limits are designed to provide reasonable protection against harmful interference when the equipment is operated in a commercial environment. This equipment generates, uses and can radiate radio frequency energy and, if not installed and used in accordance with the instruction manual, may cause harmful interference to radio communications. Operation of this equipment in a residential area is likely to cause harmful interference, in which case the user will be required to correct the interference at his personal expense.

Notice 1

The changes or modifications not expressly approved by the party responsible for compliance could void the user's authority to operate the equipment.

Notice 2

Shielded interface cables and A.C. power cord, if any, must be used in order to comply with the emission limits.



Tested To Comply
With FCC Standards
FOR HOME OR OFFICE USE

Safety Instructions

1. Always read the safety instructions carefully.
2. Keep this User's Manual for future reference.
3. Keep this equipment away from humidity.
4. Lay this equipment on a reliable flat surface before setting it up.
5. The openings on the enclosure are for air convection hence protects the equipment from overheating. DO NOT COVER THE OPENINGS.
6. Make sure the voltage of the power source and adjust properly 110/220V before connecting the equipment to the power inlet.
7. Place the power cord in such a way that people cannot step on it. Do not place anything over the power cord.
8. Always unplug the power cord before inserting any add-on card or module.
9. All cautions and warnings on the equipment should be noted.
10. Never pour any liquid into the opening. Liquid can cause damage or electrical shock.
11. If any of the following situations arises, get the equipment checked by a service personnel:
 - The power cord or plug is damaged
 - Liquid has penetrated into the equipment
 - The equipment has been exposed to moisture
 - The equipment has not work well or you cannot get it work according to User's Manual.
 - The equipment has dropped and damaged
 - If the equipment has obvious sign of breakage
12. DO NOT LEAVE THIS EQUIPMENT IN AN ENVIRONMENT UNCONDITIONED, STORAGE TEMPERATURE ABOVE 60 C (140F), IT MAY DAMAGE THE EQUIPMENT.

CAUTION: Explosion or serious damage may occur if the battery is incorrectly replaced. Replace only with the same or equivalent battery type recommended by the manufacturer.

Box CONTENTS

- One VIA Mini-ITX mainboard
- One Quick Installation Guide
- One ATA-133/100 IDE ribbon cable
- One driver and utilities CD
- One IO bracket

TABLE OF CONTENTS

Specifications	1
Mainboard Specifications	2
Mainboard Layout	4
Back Panel Layout	4
Installation	5
CPU	6
The VIA C3 E-Series Processor	6
Fans: CPUFAN, SYSFAN and PWRFAN	7
Memory Module Installation	8
DDR SDRAM Module Installation Procedures	8
Available DDR SDRAM Configurations	10
Connecting the Power Supply	11
ATX 20-Pin Power Connector	11
Back Panel Ports	13
Keyboard and Mouse	13
VGA Out	13
Serial Port: COM 1	13
RJ45 10/100 LAN Connector	14
USB 2.0 Ports	14
LPT Port	14
Audio Ports:	14
Connectors	15
Hard Disk Connectors: IDE1 & IDE2	15
Front Panel Connectors: F_PANEL	16
FIR Module Connector: FIR	17
KBMS/CIR Module Connector: KBMS	18
USB Pin Connector: USB_5/6	19
Front Audio Connector: F_AUDIO	20
LVDS Connector: LVDS (optional)	21
Wake-on LAN: WOL	22
COM Ports: COM2, COM3, COM4	23
Digital IO Connector: DIO	24

Jumpers.....	25
Clear CMOS: CLEAR_CMOS	26
COM Voltage Select: J3, J4.....	27
Slots.....	28
Peripheral Component Interconnect: PCI	28
PCI Interrupt Request Routing.....	29
BIOS Setup	31
Entering Setup	32
Control Keys.....	33
Navigating the BIOS Menus	34
Getting Help.....	35
Main Menu	36
Standard CMOS Features	36
Advanced BIOS Features.....	36
Advanced Chipset Features	36
Integrated Peripherals	36
Power Management Setup.....	36
PnP/PCI Configurations	36
PC Health Status	37
Frequency/Voltage Control	37
Load Fail-Safe Defaults	37
Load Optimized Defaults	37
Set Supervisor Password.....	37
Set User Password.....	37
Save & Exit Setup.....	37
Exit Without Saving	37
Standard CMOS Features.....	38
Date.....	38
Time	38
Halt On	38
IDE Drives	39
Advanced BIOS Features	40
Virus Warning	40

CPU L2 Cache ECC Checking	40
Processor Number Feature	40
Quick Power On Self-Test.....	41
First/Second/Third Boot Device.....	41
Boot Other Device	42
Boot Up NumLock Status.....	42
Typematic Rate Setting.....	42
Typematic Rate (Chars/Sec)	42
Typematic Delay (Msec).....	42
Security Option	43
Display Full Screen Logo	43
Show Summary Information.....	43
Display Small Logo	43
Advanced Chipset Features.....	44
AGP Aperture Size	44
AGP Mode (External)	45
AGP Fast Write.....	45
CPU to PCI POST Write	45
Select Display Device.....	45
Panel Select.....	45
CPU Direct Access FB.....	46
Integrated Peripherals.....	47
Onboard IDE Channel 1/2	47
IDE Prefetch Mode	47
Display Card Priority	47
Frame Buffer Size.....	48
AC97 Audio.....	48
VIA OnChip LAN	48
USB Keyboard Support.....	48
VIA Onboard LAN	48
Onboard Lan Boot ROM	48
Super IO Device	49
Onboard Serial Port 1/2/3/4	49

Onboard Parallel Port.....	49
Parallel Port Mode	50
EPP Mode Select	50
ECP Mode Use DMA.....	50
Onboard Fast IR.....	50
Fast IR IRQ.....	50
Fast IR DMA	51
Power Management Setup.....	52
ACPI Suspend Type	52
HDD Power Down.....	52
Power Management Timer	53
Video Off Option	53
Power Off by PWRBTN.....	53
Run VGABIOS if S3 Resume	53
AC Loss Auto restart.....	53
Peripherals Activities	54
VGA Event	54
LPT & COM Event.....	54
HDD & FDD Event	54
PCI Master Event.....	54
PS2KB Wakeup Select.....	55
PS2 Mouse Wakeup from S3/S4/S5	55
PS2 KB Wakeup from S3/S4/S5	55
USB Resume	55
PowerOn by PCI Card	55
Wake On Lan/Ring Connector.....	56
RTC Alarm Resume.....	56
Date (of Month)	56
Resume Time (hh:mm:ss).....	56
IRQs Activities	57
Primary INTR.....	57
IRQ3~IRQ15.....	57
PNP/PCI Configurations.....	58

PNP OS Installed	58
Reset Configuration Data	58
Resource Controlled By	59
Assign IRQ For VGA/USB.....	59
IRQ Resources	60
PC Health Status.....	61
Frequency / Voltage Control	62
DRAM Clock	62
DRAM Timing.....	62
DRAM CAS Latency.....	63
Bank Interleave.....	63
Precharge to Active (Trp)	63
Active to Precharge (Tras).....	63
Active to CMD (Trcd)	63
DRAM Burst Len	64
DRAM Voltage.....	64
CPU Ratio	64
Spread Spectrum.....	64
Load Fail-Safe Defaults	65
Load Optimized Defaults	66
Set Supervisor / User Password	67
Save & Exit Setup	69
Exit Without Saving	70
Driver Installation	71
Driver Utilities	72
Getting Started	72
Running the Driver Utilities CD	73
CD Content	74

CHAPTER 1

Specifications

The ultra-compact and highly integrated VIA EPIA-PE uses the Mini-ITX mainboard form-factor developed by VIA Technologies, Inc. as part of the company's open industry-wide Total Connectivity initiative. The mainboard enables the creation of an exciting new generation of small, ergonomic, innovative and affordable embedded systems. Through a high level of integration, the Mini-ITX occupies 66% of the size of FlexATX mainboard form factor. The mainboard comes with an embedded VIA Processor, boasting of ultra-low power consumption, cool and quiet operation.

MAINBOARD SPECIFICATIONS

CPU

- VIA C3 EPGA Processor

Chipset

- VIA CLE266 North Bridge
- VIA VT8235M South Bridge

Graphics

- Integrated VIA Unichrome AGP graphics with MPEG-2 Accelerator

Audio

- VIA VT1612A AC'97 Codec

Memory

- 1 x DDR266 DIMM slot (up to 1GB)

Expansion Slot

- 1 x PCI slot

IDE

- 2 x UltraDMA 66/100/133 connectors

LAN

- VIA VT6106S + VT6103 10/100 Base-T Ethernet PHY

Back Panel I/O Ports

- 1 x PS/2 mouse port and 1 x PS/2 keyboard port
- 2 x RJ-45 LAN port
- 1 x Serial port
- 1 x Parallel port
- 4 x USB 2.0 ports
- 1 x VGA port
- 3 x Audio ports: Line-out, Line-in and Mic-in

Onboard I/O Connectors

- 1 x USB pin headers for 2 additional USB 2.0 ports
- 1 x Front panel audio pinheader (Line-out and Mic-in)
- 1 x FIR pin header
- 1 x CIR pin header (Switchable for KB/MS)
- 1 x LVDS connector
- 3 x COM pin headers
- 1 x Digital IO connector
- 1 x Wake-on LAN connector
- 3 x Fan connectors

BIOS

- Award BIOS with 2/4 Mbit flash memory capacity

Form Factor

- Mini-ITX (6 layers)
- 17 cm X 17 cm

MAINBOARD LAYOUT

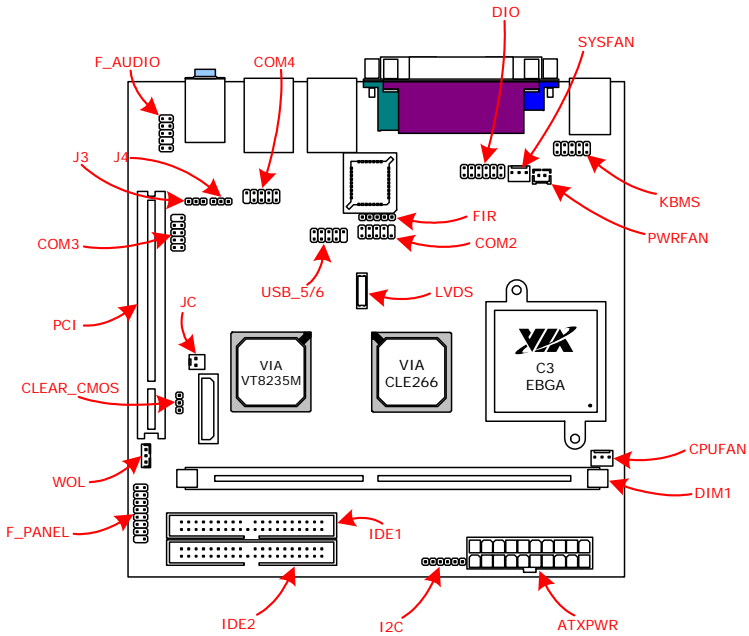

BACK PANEL LAYOUT

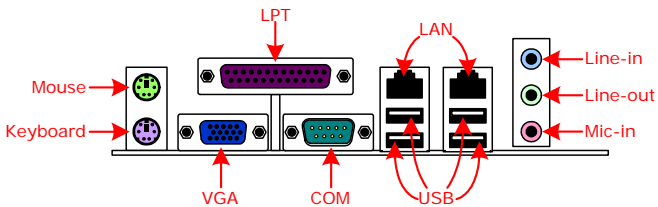

CHAPTER 2

Installation

This chapter provides you with information about hardware installation procedures. It is recommended to use a grounded wrist strap before handling computer components. Electrostatic discharge (ESD) can damage some components.

CPU

The VIA C3 E-Series Processor

The VIA EPIA-PE Mini-ITX mainboard includes an embedded VIA C3 or Eden Processor. The VIA C3 Processor provides ultra-low power consumption and advanced thermal dissipation properties. The VIA C3 Processor requires heatsink and a CPU fan to provide sufficient cooling. Ensure that the CPU fan is correctly installed as shown.

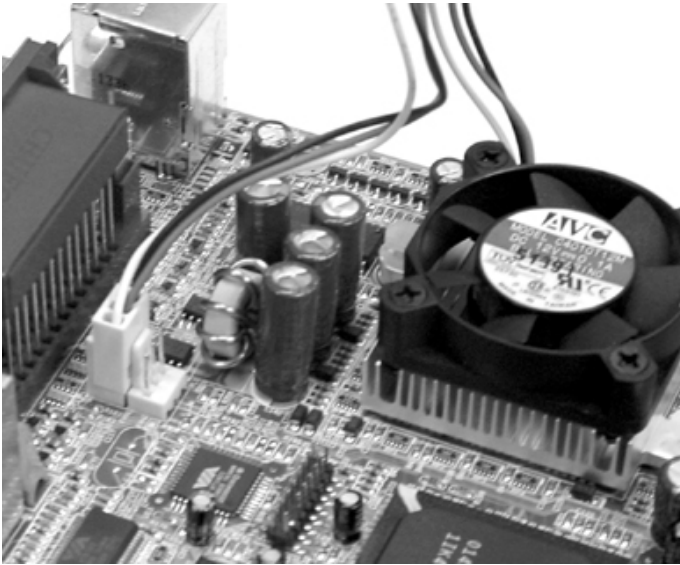

WARNING: This mainboard is not designed to support overclocking. Any attempt to operate beyond product specifications is not recommended. *We do not guarantee against damages or risks caused by inadequate operation or beyond product specifications.*

Fans: CPUFAN, SYSFAN and PWRFAN

The CPUFAN (CPU fan), SYSFAN (system fan) and PWRFAN (power fan) run on +12V and maintain system cooling. When connecting the wire to the connectors, always be aware that the red wire is the Positive and should be connected to the +12V. The black wire is Ground and should always be connected to GND. The CPU system and power fan connectors have sensors to support fan monitoring.

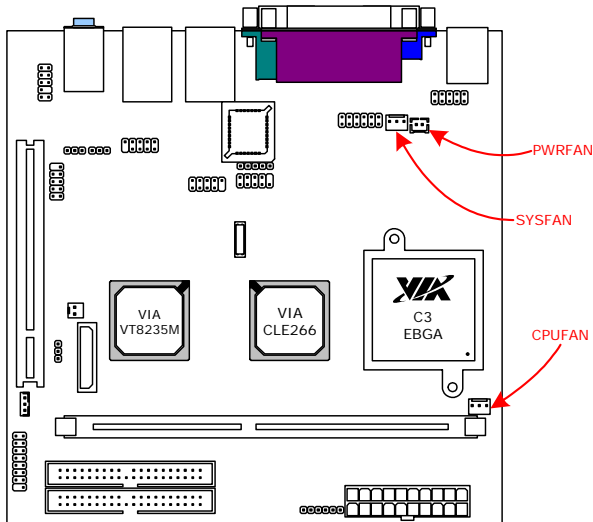

MEMORY MODULE INSTALLATION

The VIA EPIA-PE Mini-ITX mainboard provides one 184-pin DIMM slot for DDR266 SDRAM memory modules and supports memory sizes up to 1GB per slot.

DDR SDRAM Module Installation Procedures

- Locate the DIMM socket in the motherboard.

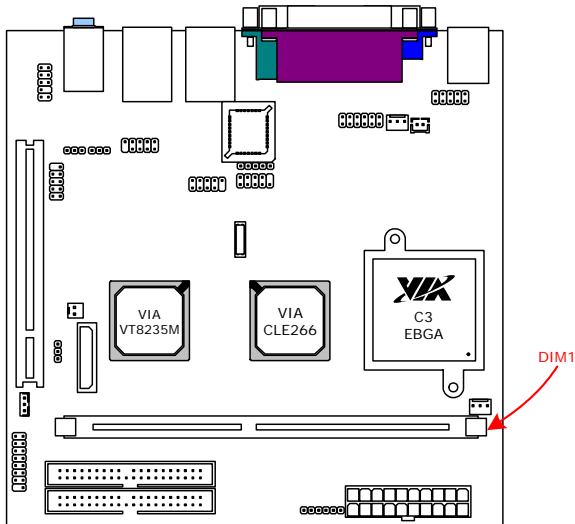

- Unlock a DIMM socket by pressing the retaining clips outward.
- Align a DIMM on the socket such that the notch on the DIMM matches the break on the socket.

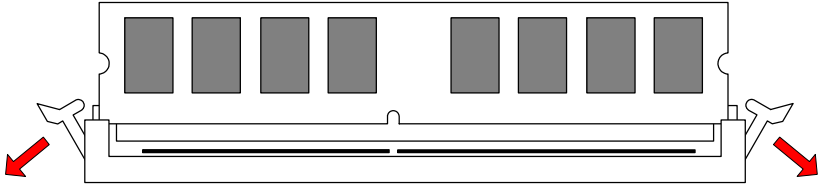

- Firmly insert the DIMM into the socket until the retaining clips snap back in place and the DIMM is properly seated.

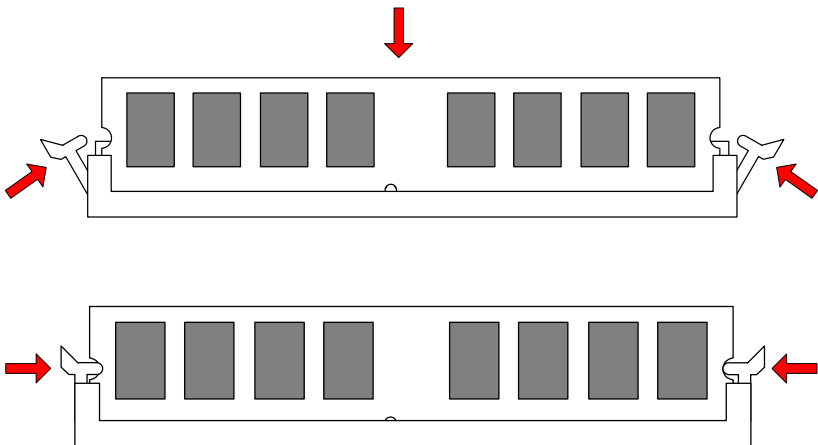

Available DDR SDRAM Configurations

Refer to the table below for available DDR SDRAM configurations on the mainboard.

Slot	Module Size	Total
DIMM 1	64MB, 128MB, 256MB, 512MB, 1GB	64MB-1GB
Maximum supported system memory		1GB

CONNECTING THE POWER SUPPLY

The VIA EPIA-PE Mini-ITX mainboard supports a conventional ATX power supply for the power system. Before inserting the power supply connector, always make sure that all components are installed correctly to ensure that no damage will be caused.

ATX 20-Pin Power Connector

To connect the ATX power supply, make sure the power plug is inserted in the proper orientation and the pins are aligned. Then push down the plug firmly into the connector.

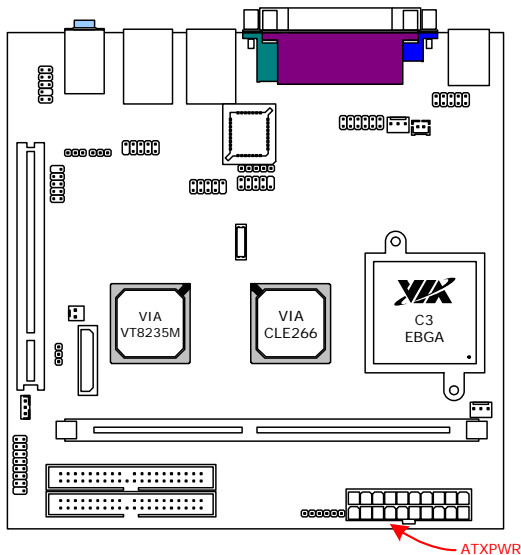

ATX 20 Pin Power Connector

Pin	Signal
1	+3.3V
2	+3.3V
3	GND
4	+5V
5	GND
6	+5V
7	GND
8	Power Good
9	+5V Standby
10	+12V

Pin	Signal
11	+3.3V
12	-12V
13	GND
14	Power Supply On
15	GND
16	GND
17	GND
18	NC
19	+5V
20	+5V

BACK PANEL PORTS

The back panel has the following ports:

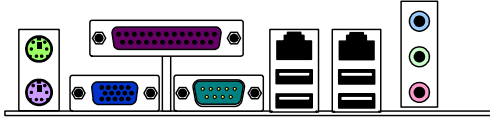

Keyboard and Mouse

The green 6-pin connector is for a PS/2 mouse. The purple connector is for a PS/2 keyboard.



VGA Out

The 15-pin female VGA connector can be used to connect to any analog VGA monitor.

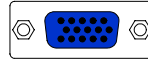

Serial Port: COM 1

This 9-pin COM 1 port is for pointing devices or other serial devices.

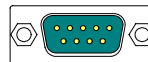

RJ45 10/100 LAN Connector

The mainboard provides a standard RJ-45 port. This port allows connection to a Local Area Network (LAN) through a network hub



USB 2.0 Ports

These four 4-pin Universal Serial Bus (USB) ports are available for connecting USB 2.0 devices.

LPT Port

The 25-pin female parallel port for connecting printers supports Enhanced Parallel Port and Extended Capabilities Port modes.

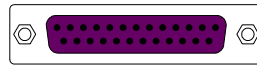

Audio Ports:

Line Out

This Line Out (lime) jack connects a headphone or a speaker.

Line In

This Line In (light blue) jack connects a tape player or other audio devices.

Microphone

This Mic (pink) jack connects a microphone.



CONNECTORS

Hard Disk Connectors: IDE1 & IDE2

The two IDE connectors support Ultra DMA 66/100/133 modes. Both IDE connectors can connect a master and a slave drive. The IDE connectors can support up to four IDE devices.

If two drives are connected to a single cable, the jumper on the second drive must be set to slave mode. Refer to the drive documentation supplied by the vendor for the jumper settings.

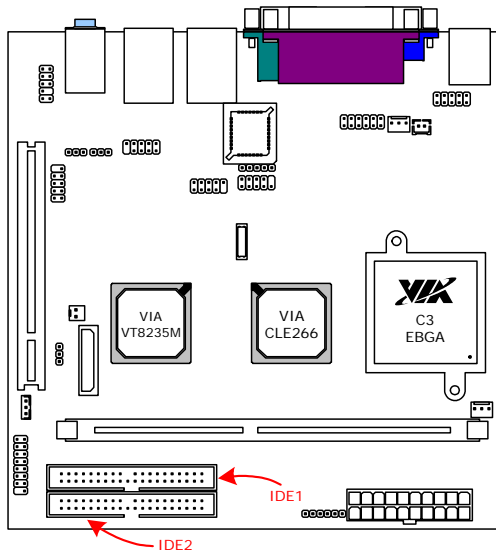

Front Panel Connectors: F_PANEL

The J3 pin header allows you to connect the power switch, reset switch, power LED, HDD LED and the case speaker.

Pin	Signal	Pin	Signal
1	HDD LED+	2	Power LED+
3	HDD LED-	4	N/A
5	Power Switch	6	Power LED-
7	Power Switch	8	N/A
9	Reset Switch	10	N/A
11	Reset Switch	12	N/A

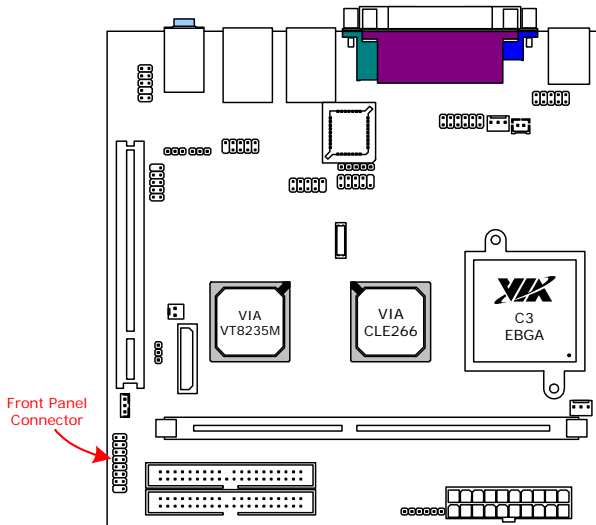

FIR Module Connector: FIR

This pin header is used to connect to a Fast IrDA module. The BIOS settings must be configured to activate the IR function.

Pin	Signal	Description
1	+3V	VCC
2	IRRX	FIR/SIR Data Receive
3	IRRX2	SIR Data Receive
4	GND	Ground
5	IRTX	FIR/SIR Data Transmit

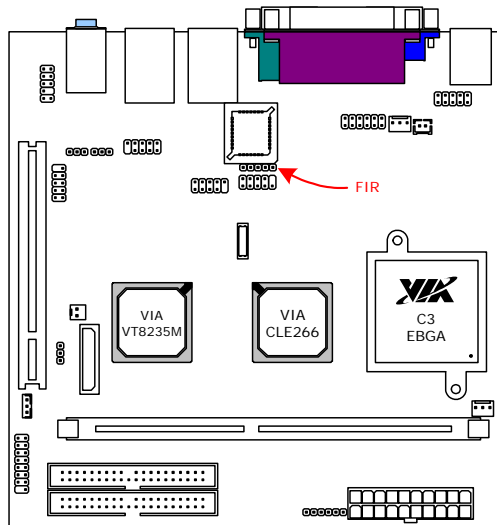

KBMS/CIR Module Connector: KBMS

This pin header is used to connect to a Consumer IrDA module.

Pin	Signal	Pin	Signal
1	+5V	2	GND
3	KB_CLK	4	KB_DATA
5	EKBCLK	6	EKBDATA
7	MS_CLK	8	MS_DATA
9	EMCLK	10	EMDATA

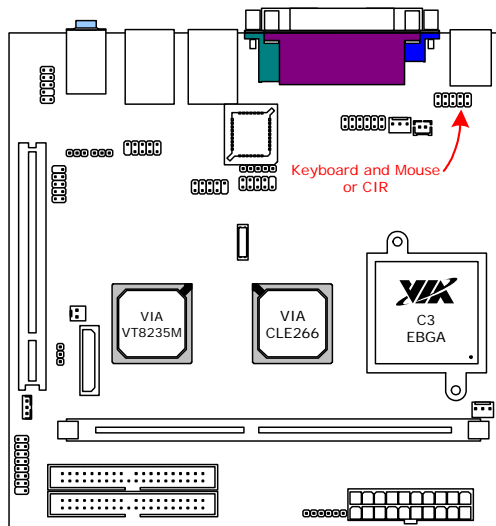

USB Pin Connector: USB_5/6

The mainboard provides 1 front USB pin header connectors, allowing up to 2 additional USB 1.1 ports. Connect each 2-port USB cable into each pin headers. These ports can be used to connect USB interface peripherals such as USB HDD, digital cameras, MP3 players, printers, modem, etc.

Pin	Signal	Pin	Signal
1	VCC	2	VCC
3	USB2-	4	USB3-
5	USB2+	6	USB3+
7	GND	8	GND
9	NC	10	GND

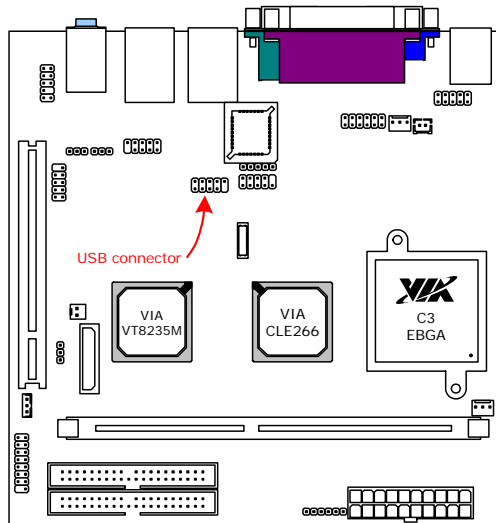

Front Audio Connector: F_AUDIO

This connector allows you to connect a front audio panel to the mainboard. Only the line-out and microphone functions are available for use on the front panel. To connect the front audio cable, first remove the two red plastic jumpers.

Pin	Signal	Pin	Signal
1	FRN_MIC	2	AGND
3	AUD_MIC_BIAS	4	+5V
5	LINE_OUT_R	6	NEXT_R
7	NC	8	Key
9	LINE_OUT_L	10	NEXT_L

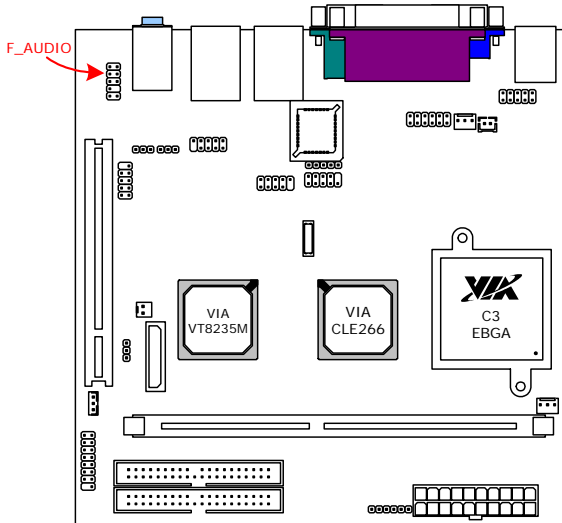

LVDS Connector: LVDS (optional)

This connector is for devices requiring access to the signals listed in the table below. The LVDS connector may not be available on your mainboard. This is an option that is added during the manufacturing process. If you would like a mainboard with the LVDS connector, please contact your vendor or sales contact for more information.

Pin	Signal	Pin	Signal	Pin	Signal	Pin	Signal
1	FPDE	2	FPD3	21	FPBKLP	22	FPD14
3	FPD0	4	FPD4	23	RESET	24	FPD15
5	FPD1	6	FPD5	25	SPCLK2	26	FPD16
7	FPD2	8	FPCLK	27	SPD2	28	FPD17
9	FPHS	10	FPD6	29	GND	30	FPD18
11	FPVS	12	FPD7	31	GND	32	FPD19
13	FPD11	14	FPD8	33	+3.3V	34	FPD20
15	FPD12	16	FPD9	35	GND	36	FPD21
17	ENPVDD	18	FPD10	37	+5V	38	FPD22
19	ENPVEE	20	FPD13	39	+5V	40	FPD23

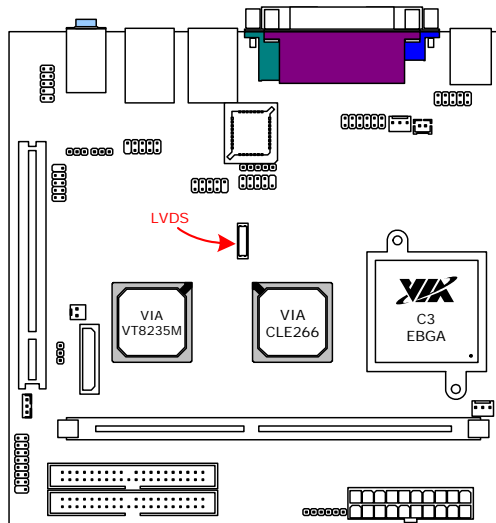

Wake-on LAN: WOL

This connector allows you to connect a network card with the Wake-On LAN function. The connector will power up the system when a signal is received through the network card. Please note that the function of ACPI WOL may be disabled when users unplug the power cord or turn off the power button manually.

Pin	Signal
1	+5VDUAL
2	GND
3	-WOL

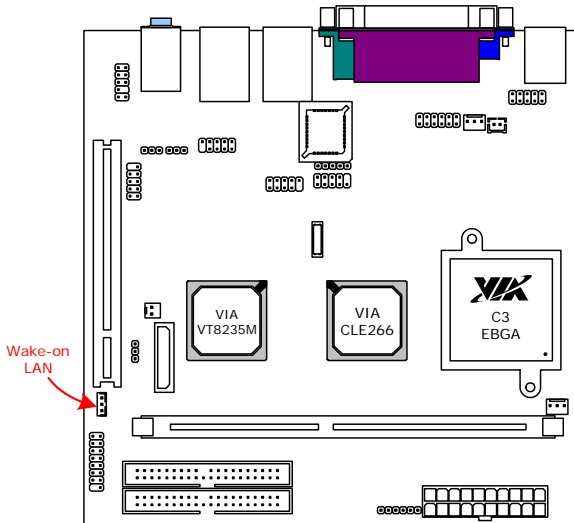

COM Ports: COM2, COM3, COM4

This mainboard has three additional COM pinheaders for enabling additional serial devices to be attached directly to the mainboard or for adding additional serial ports. COM3 and COM4 pin headers have their own voltage select jumper that enables support between either 5V or 12V. See the jumper settings for more information.

Pin	Signal	Pin	Signal
1	RIN12	2	RIN32
3	DOUT22	4	DOUT32
5	GND	6	RIN22
7	DOUT12	8	RIN42
9	XR12#	10	Key

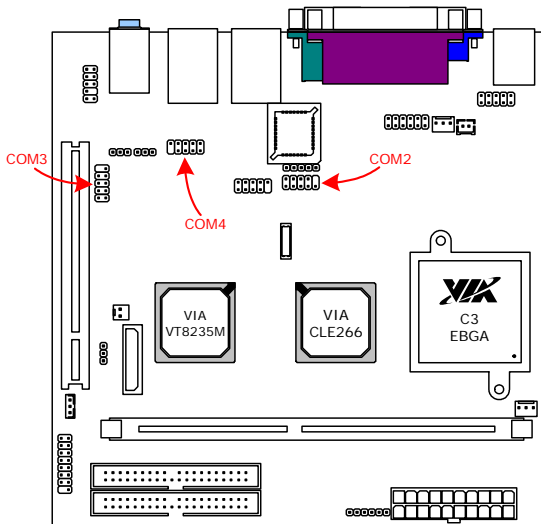

Digital IO Connector: DIO

This connector provides four GPI (General Purpose Input) and four GPO (General Purpose Output) pin headers for supporting both 5V and 12V Digital IO solutions.

Pin	Signal	Pin	Signal
1	+5V	2	+12V
3	GPO5	4	GPI10
5	GPO6	6	GPI21
7	GPO7	8	GPI28
9	GPO12	10	GPI29
11	GND	12	GND

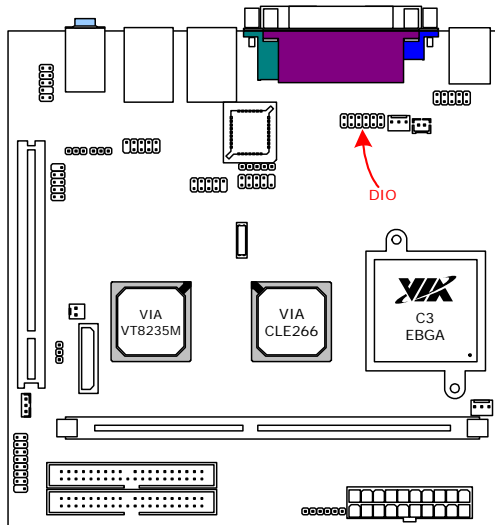

JUMPERS

The mainboard provides jumpers for setting some mainboard functions. This section will explain how to change the settings of the mainboard functions using the jumpers.

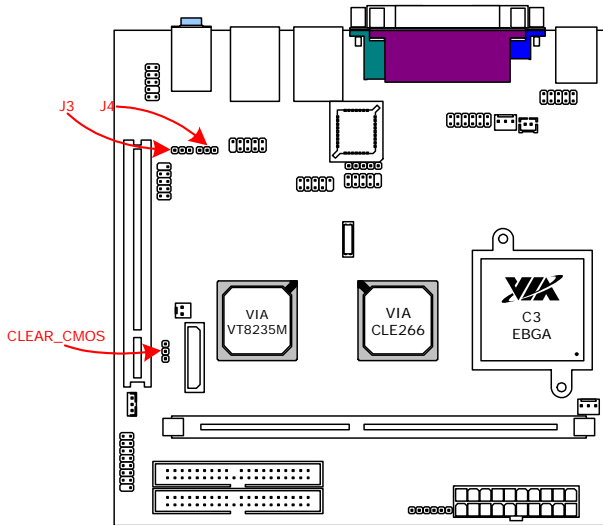

Clear CMOS: CLEAR_CMOS

This jumper allows you to clear the Real Time Clock (RTC) RAM in CMOS. You can clear the CMOS memory of date, time and system setup parameters by erasing the CMOS RTC RAM data. The onboard button cell battery powers the RAM data in CMOS that include system setup information such as system passwords.



To erase the RTC RAM:

1. Turn OFF the computer and unplug the power cord.
2. Remove the onboard battery
3. Move the jumper cap from pins 2-3 (default) to pins 1-2. Keep cap on pins 1-2 for about 5~10 seconds, then move the cap back to pins 2-3.
4. Replace the battery.
5. Plug the power cord and turn ON the computer.
6. Hold down the key during the boot process and enter BIOS setup to re-enter data.

WARNING: Except when clearing the RTC RAM, never remove the cap on CLEAR_CMOS jumper default position. Removing the cap will cause system boot failure. Avoid clearing the CMOS while the system is on; it will damage the mainboard.

COM Voltage Select: J3, J4

This jumper changes the voltage for COM3 and COM4 respectively. Voltage options are 5V and 12V.

Pins	Voltage
1-2	+5V
2-3	+12V

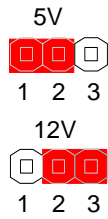

SLOTS

Peripheral Component Interconnect: PCI

The PCI slot allows you to insert PCI expansion card. When adding or removing expansion card, first unplug the power supply. Read the documentation for the expansion card if any changes to the system are necessary.

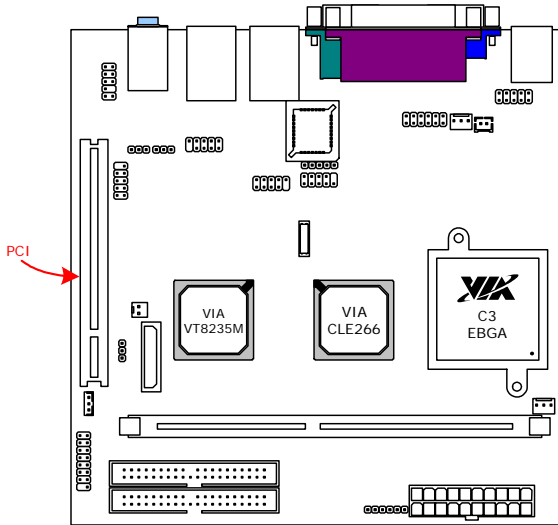

PCI Interrupt Request Routing

The IRQ (interrupt request line) are hardware lines over which devices can send interrupt signals to the microprocessor. The "PCI & LAN" IRQ pins are typically connected to the PCI bus INT A# ~ INT D# pins as follows:

	Order 1	Order 2	Order 3	Order 4
PCI Slot 1	INT B#	INT C#	INT D#	INT A#

This page is intentionally left blank.

CHAPTER 3

BIOS Setup

This chapter gives a detailed explanation of the BIOS setup functions.

ENTERING SETUP

Power on the computer and press <Delete> during the beginning of the boot sequence to enter the BIOS setup menu. If you missed the BIOS setup entry point, you may restart the system and try again.

CONTROL KEYS

Keys	Description
Up Arrow	Move to the previous item
Down Arrow	Move to the next item
Left Arrow	Move to the item in the left side
Right Arrow	Move to the item in the right side
Enter	Select the item
Escape	Jumps to the Exit menu or returns to the main menu from a submenu
Page Up / +	Increase the numeric value or make changes
Page Down / -	Decrease the numeric value or make changes
F1	General help, only for Status Page Setup Menu and Option Page Setup Menu
F5	Restore the previous CMOS value from CMOS, only for Option Page Setup Menu
F6	Load the default CMOS value from Fail-Safe default table, only for Option Page Setup Menu
F7	Load Optimized defaults
F9	Jumps to the Main Menu
F10	Save all the CMOS changes and exit

NAVIGATING THE BIOS MENUS

The main menu displays all the BIOS setup categories. Use the control keys Up/Down arrow keys to select any item/sub-menu. Description of the selected/highlighted category is displayed at the bottom of the screen.

An arrow symbol next to a field indicates that a sub-menu is available (see figure below). Press <Enter> to display the sub-menu. To exit the sub-menu, press <Esc>.

GETTING HELP

The BIOS setup program provides a "General Help" screen. You can display this screen from any menu/sub-menu by pressing <F1>. The help screen displays the keys for using and navigating the BIOS setup. Press <Esc> to exit the help screen.

MAIN MENU

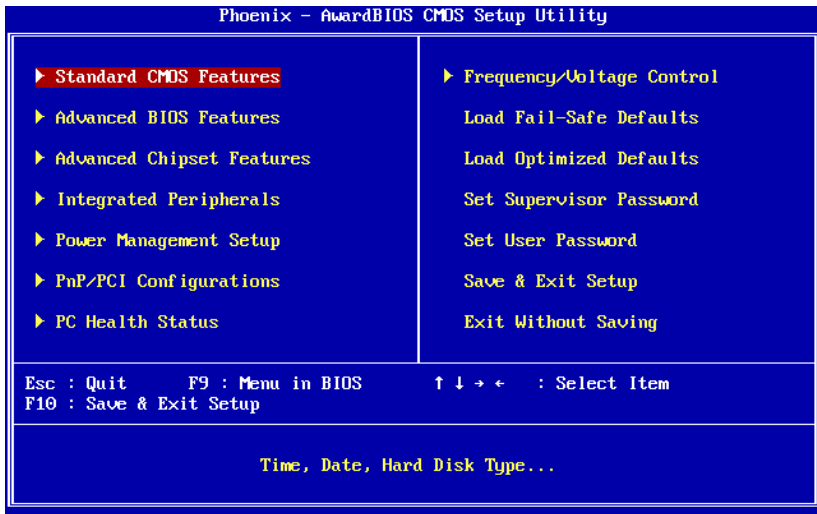

Standard CMOS Features

Use this menu to set basic system configurations.

Advanced BIOS Features

Use this menu to set the advanced features available on your system.

Advanced Chipset Features

Use this menu to set chipset specific features and optimize system performance.

Integrated Peripherals

Use this menu to set onboard peripherals features.

Power Management Setup

Use this menu to set onboard power management functions.

PnP/PCI Configurations

Use this menu to set the PnP and PCI configurations.

PC Health Status

This menu shows the PC health status.

Frequency/Voltage Control

Use this menu to set the system frequency and voltage control.

Load Fail-Safe Defaults

Use this menu option to load the BIOS default settings for minimal and stable system operations.

Load Optimized Defaults

Use this menu option to load BIOS default settings for optimal and high performance system operations.

Set Supervisor Password

Use this menu option to set the BIOS supervisor password.

Set User Password

Use this menu option to set the BIOS user password.

Save & Exit Setup

Save BIOS setting changes and exit setup.

Exit Without Saving

Discard all BIOS setting changes and exit setup.

STANDARD CMOS FEATURES

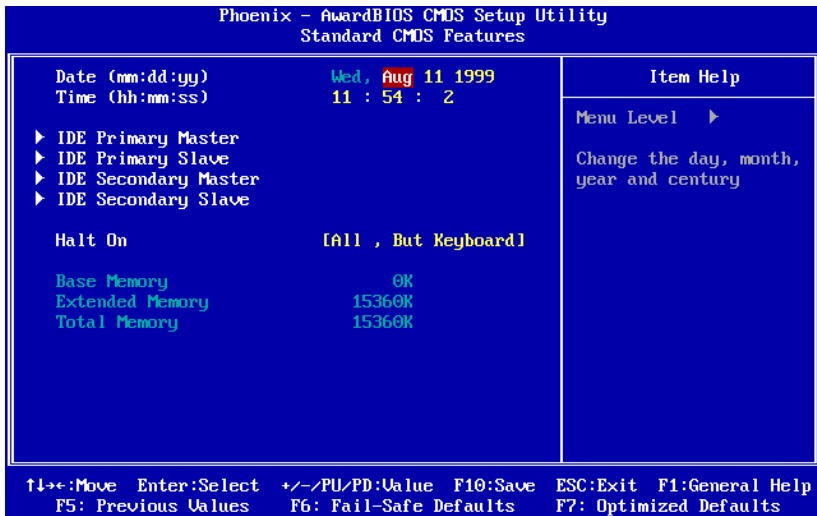

Date

The date format is [Day, Month Date Year]

Time

The time format is [Hour : Minute : Second]

Halt On

Sets the system's response to specific boot errors. Below is a table that details the possible settings.

Setting	Description
All Errors	System halts when any error is detected
No Errors	System does not halt for any error
All but Keyboard	System halts for all non-key errors

IDE DRIVES

```

Phoenix - AwardBIOS CMOS Setup Utility
IDE Primary Master

IDE HDD Auto-Detection  [Press Enter]
IDE Primary Master      [Auto]
Access Mode             [Auto]

Capacity                0 MB
Cylinder                0
Head                   0
Precomp                0
Landing Zone           0
Sector                 0

PIO Mode                [Auto]
Ultra DMA Mode         [Auto]

Item Help
Menu Level  >>
To auto-detect the
HDD's size, head... on
this channel

↑↓←→:Move  Enter:Select  +/-/PU/PD:Value  F10:Save  ESC:Exit  F1:General Help
F5: Previous Values  F6: Fail-Safe Defaults  F7: Optimized Defaults

```

The specifications of your drive must match with the drive table. The hard disk will not work properly if you enter incorrect information in this category. Select “Auto” whenever possible. If you select “Manual”, make sure the information is from your hard disk vendor or system manufacturer. Below is a table that details required hard drive information when using the “Manual” mode.

Setting	Description
IDE Channel	The name of this item will match the name of the menu (e.g. IDE Primary Master). Settings: [None, Auto, Manual]
Access Mode	Settings: [CHS, LBA, Large, Auto]
Capacity	Formatted size of the storage device
Cylinder	Number of cylinders
Head	Number of heads
Precomp	Write precompensation
Landing Zone	Cylinder location of the landing zone
Sector	Number of sectors
PIO Mode	Settings: [Auto, 0, 1, 2, 3, 4]
Ultra DMA Mode	Settings: [Auto, Disabled]

ADVANCED BIOS FEATURES

Phoenix - AwardBIOS CMOS Setup Utility Advanced BIOS Features		Item Help
Virus Warning	[Disabled]	Menu Level ▶ Allows you to choose the VIRUS warning feature for IDE Hard Disk boot sector protection. If this function is enabled and someone attempt to write data into this area , BIOS will show a warning message on screen and alarm beep
CPU L2 Cache ECC Checking	[Enabled]	
Processor Number Feature	[Enabled]	
Quick Power On Self Test	[Enabled]	
First Boot Device	[LS120]	
Second Boot Device	[SCSI]	
Third Boot Device	[HDD-0]	
Boot Other Device	[Enabled]	
Boot Up NumLock Status	[On]	
Typematic Rate Setting	[Enabled]	
Typematic Rate (Chars/Sec)	[30]	
Typematic Delay (Msec)	[250]	
Security Option	[Setup]	
Display Full Screen Logo	[Enabled]	
Show Summary Information	[Disabled]	
Display Small Logo	[Disabled]	

↑↓←→:Move Enter:Select +/-/PU/PD:Value F10:Save ESC:Exit F1:General Help
F5: Previous Values F6: Fail-Safe Defaults F7: Optimized Defaults

Virus Warning

Setting	Description
Enabled	Turns on hard disk boot sector virus protection
Disabled	Turns off hard disk boot sector virus protection

CPU L2 Cache ECC Checking

Setting	Description
Enabled	Enables ECC for L2 cache
Disabled	Disables ECC for L2 cache

Processor Number Feature

This is only valid for CPUs that have a processor number.

Setting	Description
Enabled	Enables access to the CPU's embedded unique ID number.
Disabled	Disables access to the CPU's embedded unique ID number.

Quick Power On Self-Test

Shortens Power On Self-Test (POST) cycle to enable shorter boot up time.

Setting	Description
Enabled	Shorten Power On Self Test (POST) cycle and bootup time
Disabled	Standard Power On Self Test (POST)

First/Second/Third Boot Device

Set the boot device sequence as BIOS attempts to load the disk operating system.

Setting	Description
LS120	Boot from LS-120 drive
HDD-0	Boot from the first HDD
SCSI	Boot from SCSI
CDROM	Boot from CD-ROM
HDD-1	Boot from the second HDD
HDD-2	Boot from the third HDD
HDD-3	Boot from the fourth HDD
ZIP100	Boot from ATAPI ZIP drive
USB-FDD	Boot from USB floppy drive
USB-ZIP	Boot from USB ZIP drive
USB-CDROM	Boot from USB CDROM
USB-HDD	Boot from the USB HDD.
LAN	Boot from network drive
Disabled	Disable the boot device sequence

Boot Other Device

Enables the system to boot from alternate devices if the system fails to boot from the “First/Second/Third Boot Device” list.

Setting	Description
Enabled	Enable alternate boot device
Disabled	No alternate boot device allowed

Boot Up NumLock Status

Set the NumLock status when the system is powered on.

Setting	Description
On	Forces keypad to behave as 10-key
Off	Forces keypad to behave as arrow keys

Typematic Rate Setting

Enables “Typematic Rate” and “Typematic Delay” functions.

Settings: [Enabled, Disabled]

Typematic Rate (Chars/Sec)

This item sets the rate (characters/second) at which the system retrieves a signal from a depressed key.

Settings: [6, 8, 10, 12, 15, 20, 24, 30]

Typematic Delay (Msec)

This item sets the delay between when the key was first pressed and when the system begins to repeat the signal from the depressed key.

Settings: [250, 500, 750, 1000]

Security Option

Selects whether the password is required every time the System boots, or only when you enter Setup.

Setting	Description
Setup	Password prompt appears only when end users try to run BIOS Setup
System	Password prompt appears every time when the computer is powered on and when end users try to run BIOS Setup

Display Full Screen Logo

Show full screen logo during BIOS boot up process.

Settings: [Enabled, Disabled]

Show Summary Information

Show summary screen.

Settings: [Enabled, Disabled]

Display Small Logo

Show small energy star logo during BIOS boot up process.

Settings: [Enabled, Disabled]

ADVANCED CHIPSET FEATURES

Phoenix - AwardBIOS CMOS Setup Utility		Item Help
Advanced Chipset Features		Menu Level ▶
AGP Aperture Size	[128M]	
AGP Mode(External)	[4X]	
AGP Fast Write	[Disabled]	
CPU to PCI POST Write	[Enabled]	
Select Display Device	[CRT+LCD]	
Panel Type	[1024*768]	
CPU Direct Access FB	[Enabled]	

↑↓: Move Enter: Select +/-/PU/PD: Value F10: Save ESC: Exit F1: General Help
 F5: Previous Values F6: Fail-Safe Defaults F7: Optimized Defaults

WARNING: The Advanced Chipset Features menu is used for optimizing the chipset functions. Do not change these settings unless you are familiar with the chipset.

AGP Aperture Size

This setting controls how much memory space can be allocated to AGP for video purposes. The aperture is a portion of the PCI memory address range dedicated to graphics memory address space. Host cycles that hit the aperture range are forwarded to the AGP without any translation.

Settings: [4MB, 8MB, 16MB, 32MB, 64MB, 128MB, 256MB]

AGP Mode (External)

This mainboard supports the AGP 4x interface. When the AGP 4x video card is used, it can transfer video data at 1066MB/s. AGP 4x is backward-compatible, leave the default 4x mode on if unsure. When set to 1x mode, the maximum transfer rate is at 266MB/s, and 2x mode transfers data at 533MB/s. AGP8x mode can be detected automatically once you plug in the AGP8x card.

Settings: [4X, 2X, 1X]

AGP Fast Write

This item is used to enable or disable the caching of display data for the video memory of the processor.

Settings: [Enabled, Disabled]

CPU to PCI POST Write

When Enabled, CPU can write up to four words of data to the PCI write buffer before CPU must wait for PCI bus cycle to finish. If Disabled, CPU must wait after each write cycle until PCI bus signals that it is ready to receive more data.

Settings: [Enabled, Disabled]

Select Display Device

This setting refers to the type of display being used with the system.

Settings: [CRT, LCD, CRT+LCD, DVI, CRT+DVI]

Panel Select

This setting refers to the native resolution of the display being used with the system.

Settings: [1600x1200, 1400x1050, 1280x1024, 1280x768, 1024x768, 800x600, 640x480]

CPU Direct Access FB

Controls the CPU's access to directly access the system memory reserved for graphics data.

Settings: [Enabled, Disabled]

INTEGRATED PERIPHERALS

Phoenix - AwardBIOS CMOS Setup Utility		Item Help
Integrated Peripherals		Menu Level ▶
▶ SuperIO Device	[Press Enter]	
Onboard IDE Channel 1	[Enabled]	
Onboard IDE Channel 2	[Enabled]	
IDE Prefetch Mode	[Enabled]	
Display Card Priority	[PCI Slot]	
Frame Buffer Size	[32M]	
AC97 Audio	[Auto]	
UIA OnChip LAN	[Enabled]	
USB Keyboard Support	[Disabled]	
UIA OnBoard LAN	[Enabled]	
Onboard Lan Boot ROM	[Disabled]	

↑↓: Move Enter: Select +/-/PU/PD: Value F10: Save ESC: Exit F1: General Help
 F5: Previous Values F6: Fail-Safe Defaults F7: Optimized Defaults

Onboard IDE Channel 1/2

The integrated peripheral controller contains an IDE interface with support for two IDE channels. Choose Enabled to activate each channel separately. Settings: [Enabled, Disabled]

IDE Prefetch Mode

This allows your hard disk controller to use the fast block mode to transfer data to and from the hard disk drive. Block mode is also called block transfer, multiple commands or multiple sector read/write. Enabled enables IDE controller to use block mode; Disabled allows the controller to use standard mode.

Settings: [Enabled, Disabled]

Display Card Priority

This setting specifies which VGA card is your primary graphics adapter.

Settings: [PCI Slot, AGP]

Frame Buffer Size

This setting instructs the BIOS to reserve the specified amount of memory for the internal video controller.

Settings: [16M, 32M, 64M]

AC97 Audio

Auto allows the mainboard to detect whether an audio device is used. If the device is detected, the onboard VIA AC'97 (Audio Codec'97) controller will be enabled; if not, it is disabled. Disable the controller if you want to use other controller cards to connect to an audio device.

Settings: [Auto, Disabled]

VIA OnChip LAN

This setting allows you to make VIA OnChip LAN enabled or disabled.

Settings: [Enabled, Disabled]

USB Keyboard Support

Enable USB Keyboard Support for DOS and Windows.

Settings: [Enabled, Disabled]

VIA Onboard LAN

Enables the onboard LAN controller.

Settings: [Enabled, Disabled]

Onboard Lan Boot ROM

Enable Onboard Lan Boot ROM for DOS and Windows.

Settings: [Enabled, Disabled]

SUPER IO DEVICE

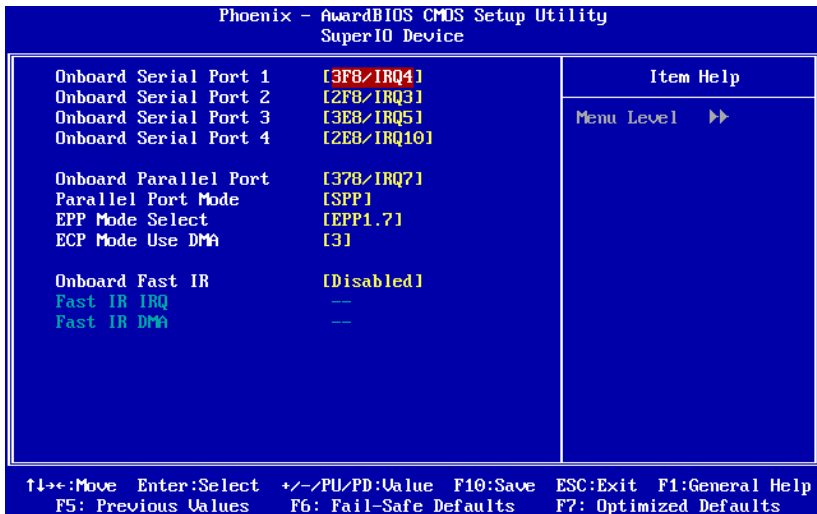

Onboard Serial Port 1/2/3/4

Set the base I/O port address and IRQ for the onboard serial port A/serial port B. Selecting Auto allows BIOS to automatically determine the correct base I/O port address.

Port	Settings					
1	Disabled	3F8 IRQ4	2F8 IRQ3	3E8 IRQ4	2E8 IRQ3	Auto
2	Disabled	3F8 IRQ4	2F8 IRQ3	3E8 IRQ4	2E8 IRQ3	Auto
3	Disabled	3F8 IRQ5	2F8 IRQ10	3E8 IRQ5	2E8 IRQ10	—
4	Disabled	3F8 IRQ5	2F8 IRQ10	3E8 IRQ5	2E8 IRQ10	—

Onboard Parallel Port

This specifies the I/O port address and IRQ of the onboard parallel port.

Settings: [Disabled, 378/IRQ7, 278/IRQ5, 3BC/IRQ7]

Parallel Port Mode

Set the parallel port mode. To operate the onboard parallel port as Standard Parallel Port, choose *SPP*. To operate the onboard parallel port in the EPP mode, choose *EPP*. By choosing *ECP*, the onboard parallel port will operate in ECP mode. Choosing *ECP + EPP* will allow the onboard parallel port to support both the ECP and EPP modes simultaneously.

Settings: [SPP, EPP, ECP, ECP + EPP]

EPP Mode Select

EPP (Enhanced Parallel Port) comes in two modes: 1.9 and 1.7. EPP 1.9 is the newer version of the protocol and is backwards compatible with most EPP devices. If your EPP device does not work with the EPP 1.9 setting, try changing the setting to EPP 1.7.

Settings: [EPP 1.9, EPP 1.7]

ECP Mode Use DMA

ECP (Extended Capabilities Port) has two DMA channels that it can use. The default channel is 3. However, some expansion cards may use channel 3 as well. To solve this conflict, change the ECP channel to 1. Select a DMA channel for the port.

Settings: [1, 3]

Onboard Fast IR

Enables the onboard FIR.

Settings: [Enabled, Disabled]

Fast IR IRQ

Set this field to reserve an IRQ for the Fast IR port. This field is only available if Onboard Fast IR is enabled.

Settings: [3, 4, 5, 11]

Fast IR DMA

Set this field to choose the DMA channel. This field is only available if Onboard Fast IR is enabled.

Settings: [6, 5]

POWER MANAGEMENT SETUP

Phoenix - AwardBIOS CMOS Setup Utility		Item Help
Power Management Setup		Menu Level ▶
ACPI Suspend Type	[S1(POS)]	This item allows you to select how the BIOS put system into power saving mode. S1(POS): System in low power mode S3(STR): All components are powered off except memory. S1 & S3: Depends on OS to select S1 or S3
HDD Power Down	[Disabled]	
Power Management Timer	[Disabled]	
Video Off Option	[Suspend -> Off]	
Power Off by PWRBTN	[Instant-Off]	
Run UGABIOS if S3 Resume	[Auto]	
AC Loss Auto restart	[Off]	
▶ Peripherals Activities	[Press Enter]	
▶ IRQs Activities	[Press Enter]	
↑↓: Move Enter: Select +/-/PU/PD: Value F10: Save ESC: Exit F1: General Help F5: Previous Values F6: Fail-Safe Defaults F7: Optimized Defaults		

ACPI Suspend Type

Setting	Description
S1(POS)	S1/Power On Suspend (POS) is a low power state. In this state, no system context (CPU or chipset) is lost and hardware maintains all system contexts.
S3(STR)	S3/Suspend To RAM (STR) is a power-down state. In this state, power is supplied only to essential components such as main memory and wakeup-capable devices. The system context is saved to main memory, and context is restored from the memory when a "wakeup" event occurs.
S1 & S3	Depends on the OS to select S1 or S3.

HDD Power Down

Sets the length of time for a period of inactivity before powering down the hard disk.

Settings: [Disabled, 1~15(minutes)]

Power Management Timer

Set the idle time before system enters power saving mode. ACPI OS such as Windows XP will override this option.

Settings: [Disabled, 1/2/4/6/8/10/20/30/40 (minutes), 1 (hour)]

Video Off Option

Select whether or not to turn off the screen when system enters power saving mode, ACPI OS such as Windows XP will override this option.

Setting	Description
Always On	Screen is always on even when system enters power saving mode
Suspend -> Off	Screen is turned off when system enters power saving mode

Power Off by PWRBTN

This field configures the power button on the chassis.

Setting	Description
Delay 4 Sec	System is turned off if power button is pressed for more than four seconds
Instant-Off	Power button functions as a normal power-on/-off button

Run VGABIOS if S3 Resume

Select whether to run VGA BIOS if resumed from S3 state. This is only necessary for older VGA drivers, select Auto if in doubt.

Settings: [Auto, Yes, No]

AC Loss Auto restart

The field defines how the system will respond after an AC power loss during system operation.

Setting	Description
Off	Keeps the system in an off state until the power button is pressed
On	Restarts the system when the power is back

PERIPHERALS ACTIVITIES

Phoenix - AwardBIOS CMOS Setup Utility		Item Help
Peripherals Activities		Menu Level ▶▶
VGA Event	[Off]	Decide whether or not the power management unit should monitor VGA activities.
LPT & COM Event	[LPT/COM]	
HDD & FDD Event	[On]	
PCI Master Event	[Off]	
PS2KB Wakeup Select	[Hot key]	
PS2MS Wakeup from S3/S4/S5	[Disabled]	
PS2KB Wakeup from S3/S4/S5	[Disabled]	
USB Resume	[Disabled]	
PowerOn by PCI Card	[Disabled]	
Wake On LAN/Ring connector	[Disabled]	
RTC Alarm Resume	[Disabled]	
Date (of Month)	--	
Resume Time (hh:mm:ss)	--:--:--	
↑↓←→:Move Enter:Select +/-/PU/PD:Value F10:Save ESC:Exit F1:General Help F5: Previous Values F6: Fail-Safe Defaults F7: Optimized Defaults		

VGA Event

Enables the power management unit to monitor VGA activities.

Settings: [Off, On]

LPT & COM Event

Decide whether or not the power management unit should monitor parallel port (LPT) and serial port (COM) activities.

Settings: [None, LPT, COM, LPT / COM]

HDD & FDD Event

Enables the power management unit to monitor hard disk and floppy disk activities.

Settings: [Off, On]

PCI Master Event

Enables the power management unit to monitor PCI master activities.

Settings: [Off, On]

PS2KB Wakeup Select

When select Password, please press Page Up or Page Down key to change Password, 8 characters maximum. Please note that PS2MS Wakeup from suspend and PS2KB Wakeup from suspend will be disabled while changing the password.

Settings: [Hot key, Password]

PS2 Mouse Wakeup from S3/S4/S5

Enables any mouse activity to restore the system from the power saving mode to an active state.

Settings: [Disabled, Enabled]

PS2 KB Wakeup from S3/S4/S5

Enables any keyboard activity to restore the system from the power saving mode to an active state.

Settings: [Disabled, Enabled]

USB Resume

Enables activity detected from USB devices to restore the system from a suspended state to an active state.

Settings: [Disabled, Enabled]

PowerOn by PCI Card

Enables activity detected from any PCI card to power up the system or resume from a suspended state. Such PCI cards include LAN, onboard USB ports, etc.

Settings: [Disabled, Enabled]

<p>NOTE: EPIA PE does not support the wake up function of a PCI Network card from the PCI PME (Power Management Event) bus.</p>
--

Wake On Lan/Ring Connector

Decide whether or not any Ring-In signals from the modem can wake up the system or resume from suspend state.

Settings: [Disabled, Enabled]

RTC Alarm Resume

Sets a scheduled time and/or date to automatically power on the system.

Settings: [Disabled, Enabled]

Date (of Month)

The field specifies the date for "RTC Alarm Resume".

Resume Time (hh:mm:ss)

The field specifies the time for "RTC Alarm Resume".

IRQs ACTIVITIES

Phoenix - AwardBIOS CMOS Setup Utility		Item Help
IRQs Activities		
Primary INTR	[On]	
IRQ3 (COM 2)	[Disabled]	
IRQ4 (COM 1)	[Enabled]	
IRQ5 (LPT 2)	[Enabled]	
IRQ6 (Floppy Disk)	[Enabled]	
IRQ7 (LPT 1)	[Enabled]	
IRQ8 (RTC Alarm)	[Disabled]	
IRQ9 (IRQ2 Redir)	[Disabled]	
IRQ10 (Reserved)	[Disabled]	
IRQ11 (Reserved)	[Disabled]	
IRQ12 (PS/2 Mouse)	[Enabled]	
IRQ13 (Coprocessor)	[Enabled]	
IRQ14 (Hard Disk)	[Enabled]	
IRQ15 (Reserved)	[Disabled]	
		Menu Level >>
		If you choose Disabled , the power management unit will not monitor any IRQ activities.
↑↓: Move Enter: Select +/-/PU/PD: Value F10: Save ESC: Exit F1: General Help F5: Previous Values F6: Fail-Safe Defaults F7: Optimized Defaults		

Primary INTR

Restores the system to an active state if IRQ activity is detected from any of the enabled channels

Settings: [Off, On]

IRQ3~IRQ15

Enables or disables the monitoring of the specified IRQ line. These fields are only available if "Primary INTR" is on.

Settings: [Enabled, Disabled]

NOTE: IRQ (Interrupt Request) lines are system resources allocated to I/O devices. When an I/O device needs to gain attention of the operating system, it signals this by causing an IRQ to occur. After receiving the signal, when the operating system is ready, the system will interrupt itself and perform the service required by the IO device.

PNP/PCI CONFIGURATIONS

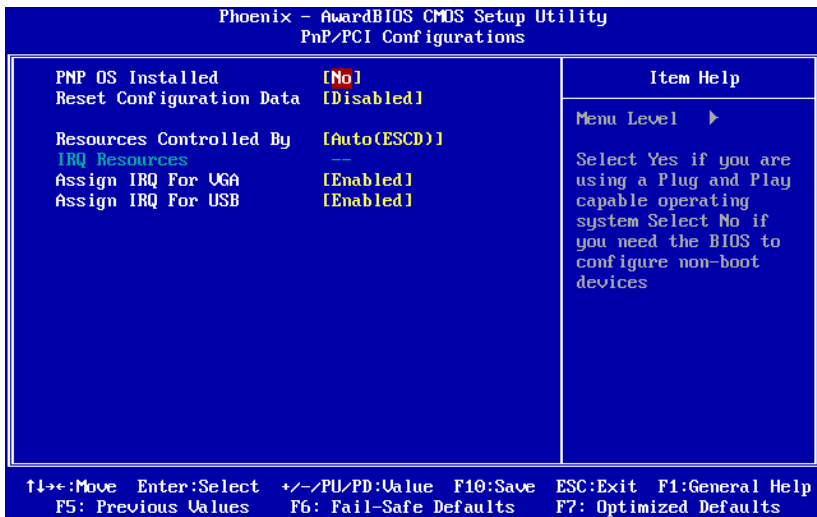

NOTE: This section covers some very technical items and it is strongly recommended to leave the default settings as is unless you are an experienced user.

PNP OS Installed

Setting	Description
Yes	BIOS will only initialize the PnP cards used for booting (VGA, IDE, SCSI). The rest of the cards will be initialized by the PnP operating system
No	BIOS will initialize all the PnP cards

Reset Configuration Data

This field should usually be left "Disabled".

Setting	Description
Enabled	Resets the ESCD (Extended System Configuration Data) after exiting BIOS Setup if a newly installed PCI card or the system configuration prevents the operating system from loading
Disabled	Default setting

Resource Controlled By

Enables the BIOS to automatically configure all the Plug-and-Play compatible devices.

Setting	Description
Auto(ESCD)	BIOS will automatically assign IRQ, DMA and memory base address fields
Manual	Unlocks "IRQ Resources" for manual configuration

Assign IRQ For VGA/USB

Assign IRQ for VGA and USB devices.

Settings: [Disabled, Enabled]

IRQ RESOURCES

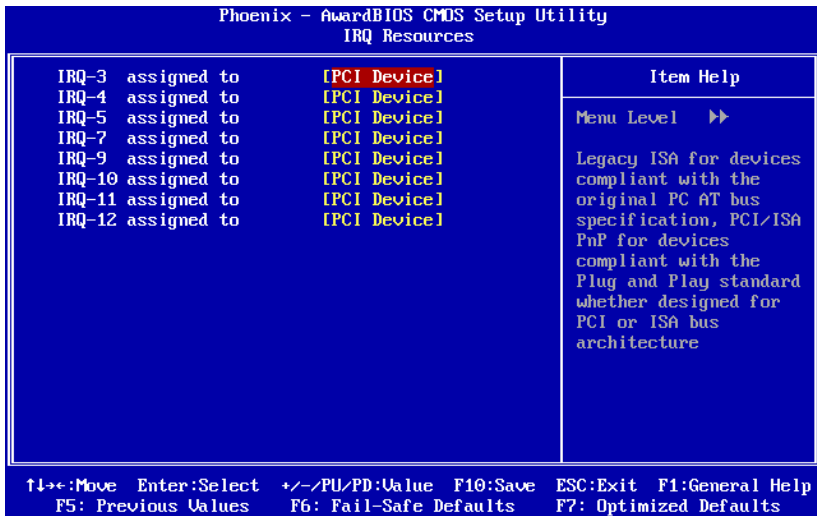

NOTE: The items are adjustable only when “Resources Controlled By” is set to “Manual.”

IRQ Resources list IRQ 3/4/5/7/9/10/11/12/14/15 for users to set each IRQ a type depending on the type of device using the IRQ.

Setting	Description
PCI Device	For Plug-and-Play compatible devices designed for PCI bus architecture
Reserved	The IRQ will be reserved for other requests

PC HEALTH STATUS

Phoenix - AwardBIOS CMOS Setup Utility	
PC Health Status	
	Item Help
System Fan Speed	
CPU Fan Speed	
5USB	
+5V	
CPU Ucore	
3.3V	
+12V	
	Menu Level ▶

↑↓←→:Move Enter:Select +/-/PU/PD:Value F10:Save ESC:Exit F1:General Help
F5: Previous Values F6: Fail-Safe Defaults F7: Optimized Defaults

The PC Health Status displays the current status of all of the monitored hardware devices/components such as CPU voltages, temperatures and fan speeds.

FREQUENCY / VOLTAGE CONTROL

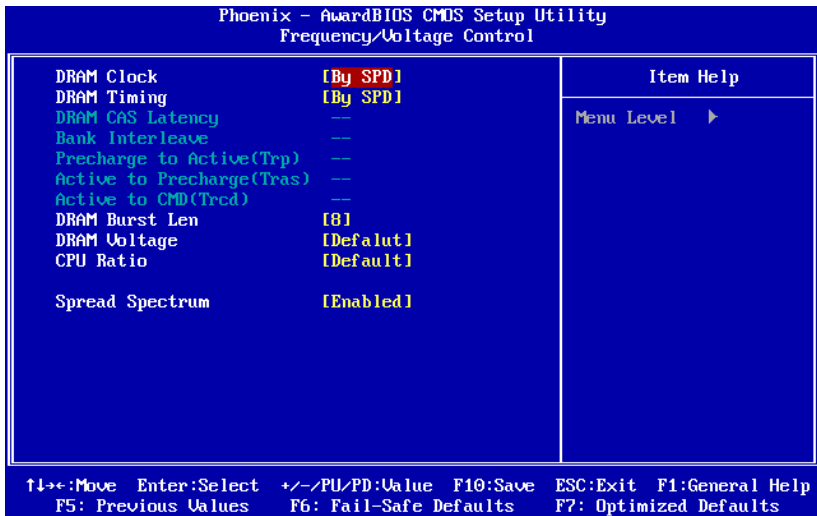

DRAM Clock

The chipset supports synchronous and asynchronous mode between host clock and DRAM clock frequency.

Settings: 66 MHz, 100 MHz, 133 MHz, By SPD

DRAM Timing

The value in this field depends on the memory modules installed in your system. Changing the value from the factory setting is not recommended unless you install new memory that has a different performance rating than the original modules.

Settings: [Manual, By SPD]

DRAM CAS Latency

This item adjusts the speed it takes for the memory module to complete a command. Generally, a lower setting will improve the performance of your system. However, if your system becomes less stable, you should change it to a higher setting. This field is only available when DRAM Timing is set to Manual.

Settings: [2, 2.5]

Bank Interleave

Set the interleave mode of the SDRAM interface. Interleaving allows banks of SDRAM to alternate their refresh and access cycles. One bank will undergo its refresh cycle while another is being accessed. This improves performance of the SDRAM by masking the refresh time of each bank. This field is only available when DRAM Timing is set to Manual.

Settings: [Disabled, 2 Bank, 4 Bank]

Precharge to Active (Trp)

This field controls the length of time it takes to precharge a row in the memory module before the row becomes active. Longer values are safer but may not offer the best performance. This field is only available when DRAM Timing is set to Manual.

Settings: [2T, 3T]

Active to Precharge (Tras)

This field controls the length of time it a row stays active before precharging. Longer values are safer buy may not offer the best performance. This field is only available when DRAM Timing is set to Manual.

Settings: [5T, 6T]

Active to CMD (Trcd)

This field is only available when DRAM Timing is set to Manual.

Settings: [2T, 3T]

DRAM Burst Len

This field sets the length of time for one burst of data during a read/write transaction. Longer settings equals better memory performance.

Settings: [4, 8]

DRAM Voltage

This field sets the voltage for the memory module.

Settings: [2.7V, 2.6V, 2.5V, Default]

CPU Ratio

Settings: [Default, x3, x3.5, x4, x4.5, x5, x5.5, x6, x6.5, x7, x7.5, x8, x8.5, x9, x9.5, x10, x10.5, x11, x11.5, x12, x13, x14, x15, x16]

Spread Spectrum

When the mainboard's clock generator pulses, the extreme values (spikes) of the pulses creates EMI (Electromagnetic Interference). The Spread Spectrum function reduces the EMI generated by modulating the pulses so that the spikes of the pulses are reduced to flatter curves.

LOAD FAIL-SAFE DEFAULTS

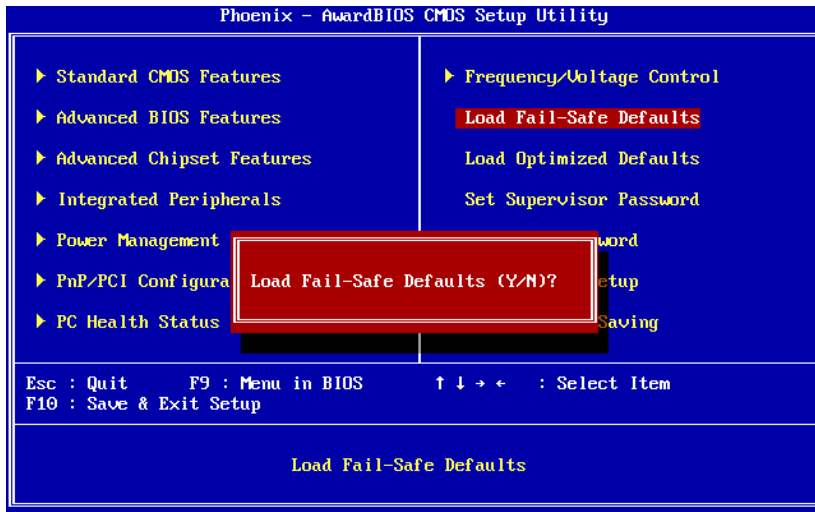

This option is for restoring all the default fail-safe BIOS settings. These values are set by the mainboard manufacturer to provide a stable system with basic performance.

Entering "Y" loads the default fail-safe BIOS values.

LOAD OPTIMIZED DEFAULTS

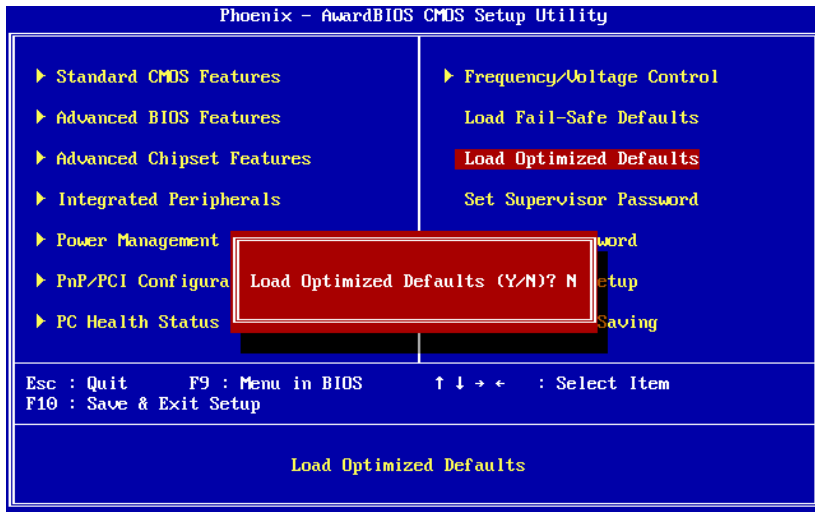

This option is for restoring all the default optimized BIOS settings. The default optimized values are set by the mainboard manufacturer to provide a stable system with optimized performance.

Entering "Y" loads the default optimized BIOS values.

SET SUPERVISOR / USER PASSWORD

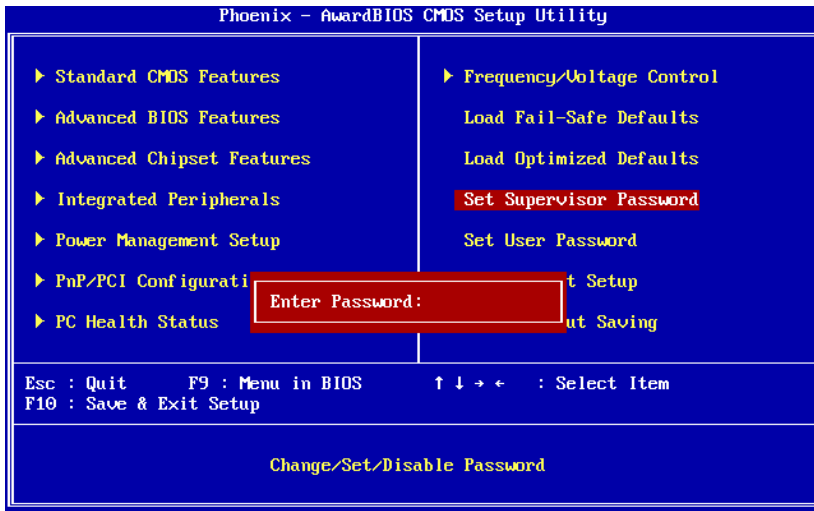

This option is for setting a password for entering BIOS Setup. When a password has been set, a password prompt will be displayed whenever BIOS Setup is run. This prevents an unauthorized person from changing any part of your system configuration.

There are two types of passwords you can set. A supervisor password and a user password. When a supervisor password is used, the BIOS Setup program can be accessed and the BIOS settings can be changed. When a user password is used, the BIOS Setup program can be accessed but the BIOS settings cannot be changed.

To set the password, type the password (up to eight characters in length) and press <Enter>. The password typed now will clear any previously set password from CMOS memory. The new password will need to be reentered to be confirmed. To cancel the process press <Esc>.

To disable the password, press <Enter> when prompted to enter a new password. A message will show up to confirm disabling the password. To cancel the process press <Esc>.

Additionally, when a password is enabled, the BIOS can be set to request the password each time the system is booted. This would prevent unauthorized use of the system. See “Security Option” in the “Advanced BIOS Features” section for more details.

SAVE & EXIT SETUP

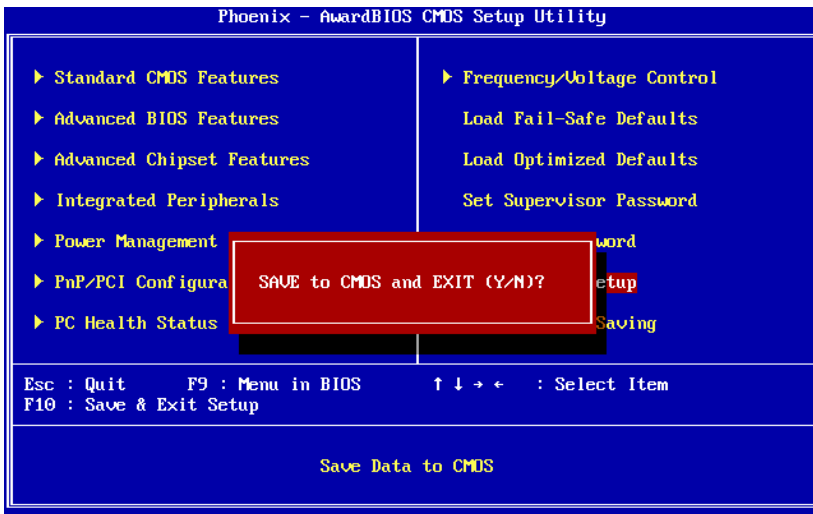

Entering "Y" saves any changes made and exits the program.

Entering "N" will cancel the exit request.

EXIT WITHOUT SAVING

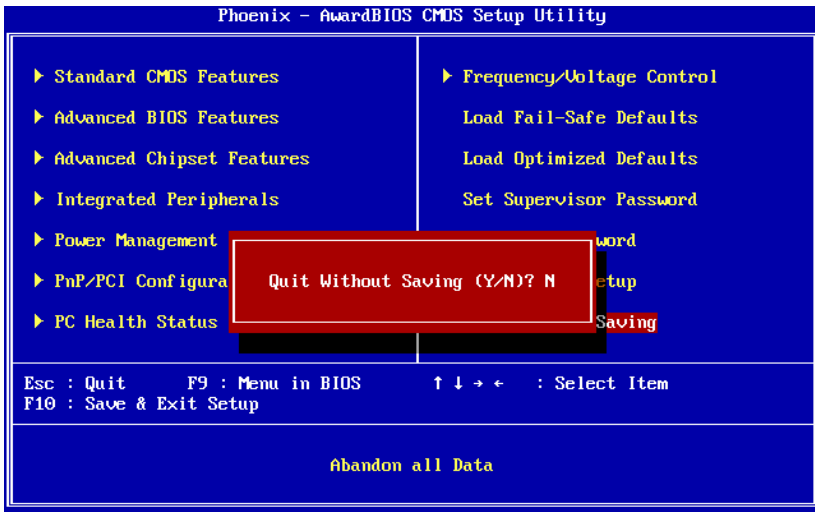

Entering "Y" discards any changes made and exits the program.

Entering "N" will cancel the exit request.

CHAPTER 4

Driver Installation

This chapter gives you brief descriptions of each mainboard driver and application. You must install the VIA chipset drivers first before installing other drivers such as audio or VGA drivers. The applications will only function correctly if the necessary drivers are already installed.

DRIVER UTILITIES

Getting Started

The mainboard includes a Driver Utilities CD that contains the driver utilities and software for enhancing the performance of the mainboard. If the CD is missing from the retail box, please contact the local dealer for the CD.

Note: The driver utilities and software are updated from time to time. The latest updated versions are available at <http://www.viaembedded.com/>

Running the Driver Utilities CD

To start using the CD, insert the CD into the CD-ROM or DVD-ROM drive. The CD should run automatically after closing the CD-ROM or DVD-ROM drive. The driver utilities and software menu screen should then appear on the screen. If the CD does not run automatically, click on the "Start" button and select "Run..." Then type: "D:\Setup.exe".

NOTE: D: might not be the drive letter of the CD-ROM/DVD-ROM in your system.

CD CONTENT

- VIA 4in1 Drivers:** Contains VIA ATAPI Vendor Support Driver (enables the performance enhancing bus mastering functions on ATA-capable Hard Disk Drives and ensures IDE device compatibility), AGP VxD Driver (provides service routines to your VGA driver and interface directly to hardware, providing fast graphical access), IRQ Routing Miniport Driver (sets the system's PCI IRQ routing sequence) and VIA INF Driver (enables the VIA Power Management function).
- VIA Graphics Driver:** Enhances the onboard VIA graphic chip.
- VIA Audio Driver:** Enhances the onboard VIA audio chip.
- VIA USB 2.0 Driver:** Enhances VIA USB 2.0 ports.
- VIA LAN Driver:** Enhances the onboard VIA LAN chip.
- VIA FIR Driver:** Support for FIR.

Note: The EPIA-PE is packaged with the same driver installation CD as the EPIA-PD.