

User's Manual

EPIA-LT

Version 1.04
January 15, 2008

Copyright

Copyright © 2005-2008 VIA Technologies Incorporated. All rights reserved.

No part of this document may be reproduced, transmitted, transcribed, stored in a retrieval system, or translated into any language, in any form or by any means, electronic, mechanical, magnetic, optical, chemical, manual or otherwise without the prior written permission of VIA Technologies, Incorporated.

Trademarks

All trademarks are the property of their respective holders. PS/2 is a registered trademark of IBM Corporation. Award BIOS is a registered trademark of Phoenix Technologies Ltd.

Macrovision

Apparatus Claims of U.S. Patent Nos. 4,631,603; 4,819,098; 4,907,093; 5,315,448; 6,516,132 licensed for limited viewing uses only. This product incorporates copyright protection technology that is protected by certain U.S. patents and other intellectual property rights owned by Macrovision and other rights owners. Use of this copyright protection technology must be authorized by Macrovision, and is intended for home and other limited viewing uses only unless otherwise authorized by Macrovision. Reverse engineering or disassembly is prohibited.

Disclaimer

No license is granted, implied or otherwise, under any patent or patent rights of VIA Technologies. VIA Technologies makes no warranties, implied or otherwise, in regard to this document and to the products described in this document. The information provided in this document is believed to be accurate and reliable as of the publication date of this document. However, VIA Technologies assumes no responsibility for the use or misuse of the information in this document and for any patent infringements that may arise from the use of this document. The information and product specifications within this document are subject to change at any time, without notice and without obligation to notify any person of such change.

FCC-B Radio Frequency Interference Statement

This equipment has been tested and found to comply with the limits for a class B digital device, pursuant to part 15 of the FCC rules. These limits are designed to provide reasonable protection against harmful interference when the equipment is operated in a commercial environment. This equipment generates, uses and can radiate radio frequency energy and, if not installed and used in accordance with the instruction manual, may cause harmful interference to radio communications. Operation of this equipment in a residential area is likely to cause harmful interference, in which case the user will be required to correct the interference at his personal expense.

Notice 1

The changes or modifications not expressly approved by the party responsible for compliance could void the user's authority to operate the equipment.

Notice 2

Shielded interface cables and A.C. power cord, if any, must be used in order to comply with the emission limits.



Tested To Comply
With FCC Standards
FOR HOME OR OFFICE USE

Safety Instructions

1. Always read the safety instructions carefully.
2. Keep this User's Manual for future reference.
3. Keep this equipment away from humidity.
4. Lay this equipment on a reliable flat surface before setting it up.
5. The openings on the enclosure are for air convection hence protects the equipment from overheating. DO NOT COVER THE OPENINGS.
6. Make sure the voltage of the power source and adjust properly 110/220V before connecting the equipment to the power inlet.
7. Place the power cord in such a way that people cannot step on it. Do not place anything over the power cord.
8. Always unplug the power cord before inserting any add-on card or module.
9. All cautions and warnings on the equipment should be noted.
10. Never pour any liquid into the opening. Liquid can cause damage or electrical shock.
11. If any of the following situations arises, get the equipment checked by a service personnel:
 - The power cord or plug is damaged
 - Liquid has penetrated into the equipment
 - The equipment has been exposed to moisture
 - The equipment has not work well or you cannot get it work according to User's Manual.
 - The equipment has dropped and damaged
 - If the equipment has obvious sign of breakage
12. DO NOT LEAVE THIS EQUIPMENT IN AN ENVIRONMENT UNCONDITIONED, OR IN A STORAGE TEMPERATURE ABOVE 60°C (140°F). THE EQUIPMENT MAY BE DAMAGED.

CAUTION: Explosion or serious damage may occur if the battery is incorrectly replaced. Replace only with the same or equivalent battery type recommended by the manufacturer.

Box CONTENTS

- ☒ One VIA Mini-ITX mainboard
- ☒ One ATA-133/100 IDE ribbon cable
- ☒ One driver and utilities CD
- ☒ One IO bracket

TABLE OF CONTENTS

Box Contents.....	i
Table of Contents	ii
Chapter 1	1
Specifications	1
Mainboard Specifications	2
Mainboard Layout.....	4
Back Panel Layout	5
Chapter 2	6
Installation.....	6
CPU	7
Memory Module Installation	9
Connecting the Power Supply	10
Back Panel Ports	11
Connectors.....	13
Jumpers.....	20
Slots	22
Chapter 3	23
BIOS Setup	23
Entering Setup.....	24
Control Keys.....	25
Getting Help.....	26
Main Menu	27
Advanced Settings.....	28
CPU Configuration	29
IDE Configuration.....	30
IDE Drives	31
SuperI/O Configuration	33
Hardware Health Configuration.....	35
ACPI Settings	36
General ACPI Configuration.....	37
Advanced ACPI Configuration	38
Chipset ACPI Configuration.....	39
APM Configuration.....	40
Remote Access Configuration	43

USB Configuration	44
Advanced PCIPnP Settings	46
Boot Settings	48
Boot Settings Configuration	49
Boot Device Priority	50
Security Settings	51
Advanced Chipset Settings	52
NorthBridge VIA CX700 Configuration	53
OnChip VGA Configuration	54
SouthBridge VIA CX700 Configuration	56
Exit Options	57
Chapter 4	58
Driver Installation	58
Driver Utilities	59
CD Content	61

CHAPTER 1

Specifications

The ultra-compact and highly integrated VIA EPIA-LT uses the Mini-ITX mainboard form-factor developed by VIA Technologies, Inc. as part of the company's open industry-wide total connectivity initiative. The mainboard enables the creation of an exciting new generation of small, ergonomic, innovative and affordable embedded systems. Through a high level of integration, the Mini-ITX occupy 66% of the size of FlexATX mainboard form factor. The mainboard comes with an embedded VIA Processor, boasting of ultra-low power consumption, cool and quiet operation.

MAINBOARD SPECIFICATIONS

CPU

- VIA C7® 1.5GHz / 1.0GHz NanoBGA2 Processor

Chipset

- VIA CX700 Advanced All-in-One system processor

Graphics

- Integrated UniChrome™ Pro II 3D/2D AGP graphics with MPEG-2 video decoding acceleration

Audio

- VIA VT1708A High Definition Audio Codec

Memory

- 1 x DDR2 533 DIMM slot (up to 1 GB)

Expansion Slot

- 1 x PCI slot

IDE

- 1 x UltraDMA 133/100/66 connector

Serial ATA

- 2 x SATA connectors

LAN

- VIA VT6107 10/100 Mbps Fast Ethernet Controller
- VIA VT6107 10/100 Mbps Fast Ethernet Controller or VIA VT6122 Gigabit LAN Controller (Manufacturing Option)

Back Panel I/O Ports

- 1 x PS/2 mouse port and 1 x PS/2 keyboard port
- 2 x RJ45 LAN port
- 1 x VGA port
- 1 x COM port
- 4 x USB 2.0 ports
- 3 x Audio jacks: Line-out, Line-in and Mic-in

Onboard I/O Connectors

- 3 x Serial port pin headers for COM2/3/4 (with 5V/12V select jumper)
- 1 x Digital I/O pin header
- 1 x USB pin header for 2 USB 2.0 ports
- 1 x LPC connector
- 1 x SMBus & Security pin header
- 1 x Front Panel Audio pin header
- 1 x Parallel Port pin header
- 1 x LVDS Module connector
- 1 x LVDS Panel Power Selector pin header
- 1 x LVDS Inverter pin header
- 1 x CIR pin header (Convertible to KB/MS)
- 2 x Fan connector for CPU fan & SYS fan
- 1 x Front Panel connector
- 1 x ATX Power connector
- 1 x TV-out pin header (Manufacturing Option with CX700M2)

BIOS

- AMI BIOS with LPC 2/4/8Mbit flash memory capacity

Form Factor

- Mini-ITX (6 layers)
- 17 cm X 17 cm

Note:

Due to the hardware limitation, DDR2 SDRAM chips organized as 128Mb x 8 bank cannot be supported by EPIA products with CN700 and CX700M2 chipsets.

MAINBOARD LAYOUT

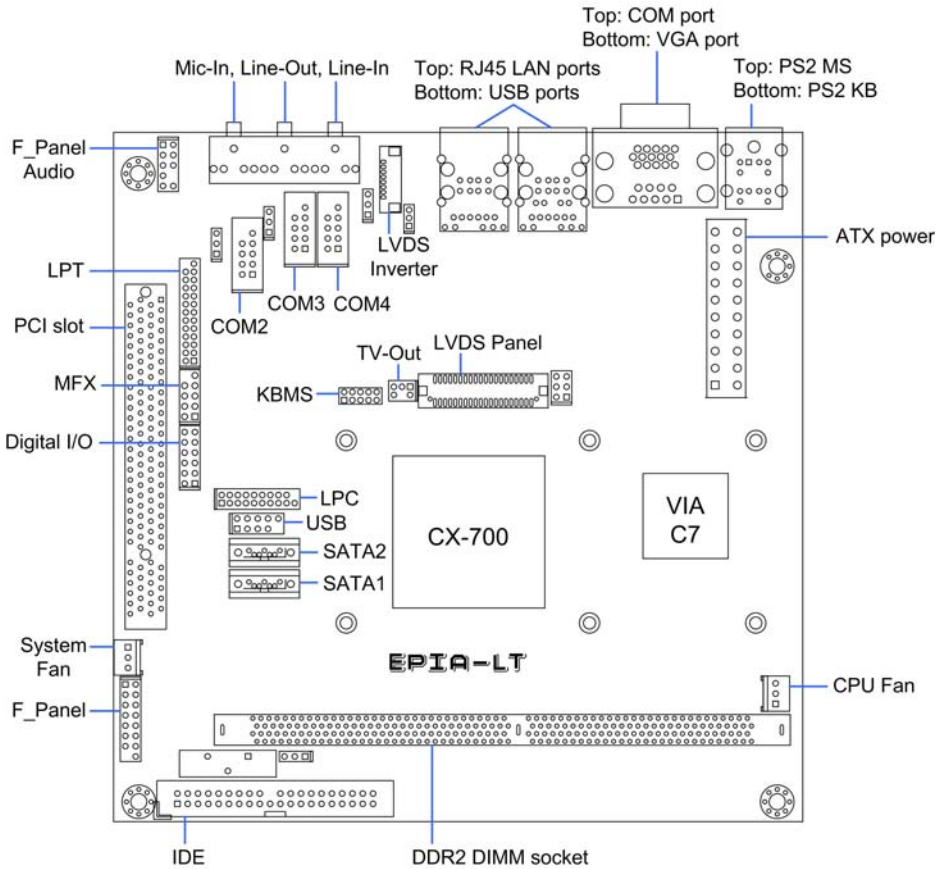

BACK PANEL LAYOUT

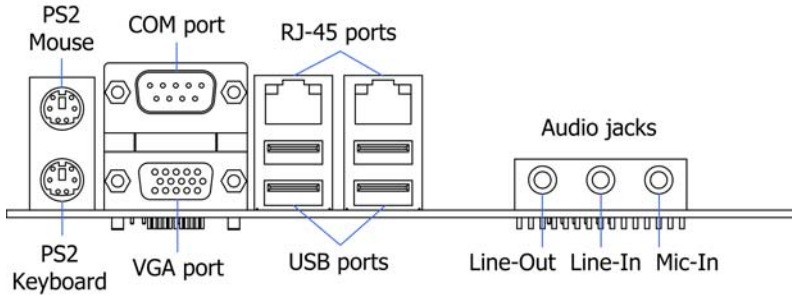

CHAPTER 2

Installation

This chapter provides you with information about hardware installation procedures. It is recommended to use a grounded wrist strap before handling computer components. Electrostatic discharge (ESD) can damage some components.

CPU

The VIA EPIA-LT Mini-ITX mainboard includes an embedded VIA C7 V4 Bus Processor. The VIA C7 V4 Bus Processor requires only a heatsink to provide sufficient cooling.

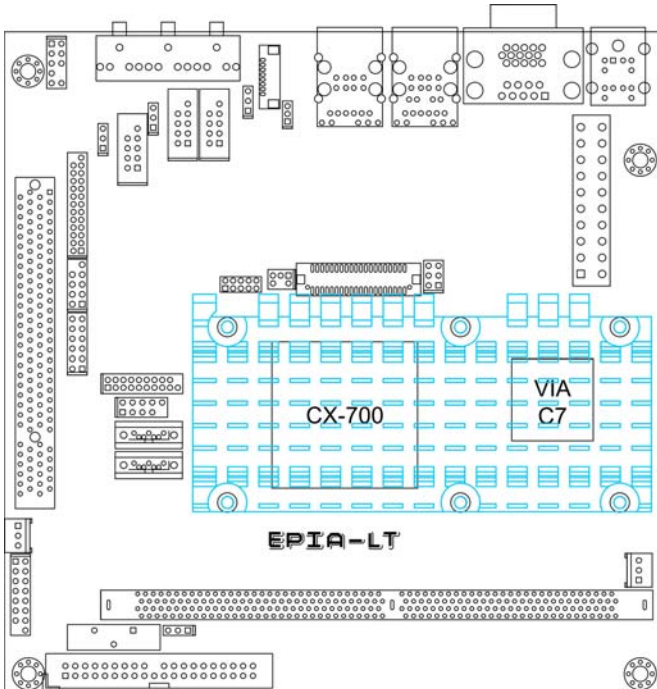

CPU Fan and System Fan: CPUFAN and SYSFAN

The CPUFAN (CPU fan) and SYSFAN (system fan) run on +12V and maintain system cooling. When connecting the wire to the connectors, always be aware that the red wire is the Positive and should be connected to the +12V. The black wire is Ground and should always be connected to GND.

CPUFAN

Pin	Signal
1	NC
2	+12V
3	GND

CPUFAN

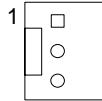

SYSFAN

Pin	Signal
1	NC
2	+12V
3	GND

SYSFAN

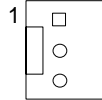

MEMORY MODULE INSTALLATION

The VIA EPIA-LT Mini-ITX mainboard provides one 240-pin DIMM slot for DDR2 533 SDRAM memory modules and supports the memory size up to 1GB.

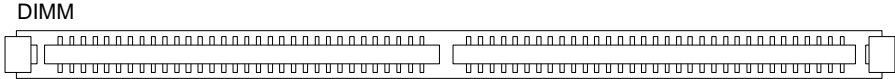

DDR SDRAM Module Installation Procedures

- Locate the DIMM slot in the motherboard.
- Unlock a DIMM slot by pressing the retaining clips outward.
- Align a DIMM on the socket such that the notch on the DIMM matches the break on the slot.
- Firmly insert the DIMM into the slot until the retaining clips snap back in place and the DIMM is properly seated.

Available DDR SDRAM Configurations

Refer to the table below for available DDR SDRAM configurations on the mainboard.

Slot	Module Size	Total
DIMM	64MB, 128MB, 256MB, 512MB, 1GB	64MB-1GB
Maximum supported system memory		64MB-1GB

NOTE: Only supports 1GB SDRAM with 64M x 8bits x16 configuration.

CONNECTING THE POWER SUPPLY

The VIA EPIA-LT Mini-ITX mainboard supports a conventional ATX power supply for the power system. Before inserting the power supply connector, always make sure that all components are installed correctly to ensure that no damage will be caused.

ATX 20-Pin Power Connector

To connect the ATX power supply, make sure the power plug is inserted in the proper orientation and the pins are aligned. Then push down the plug firmly into the connector.

Pin	Signal
1	+3.3V
2	+3.3V
3	GND
4	+5V
5	GND
6	+5V
7	GND
8	Power Good
9	+5V Standby
10	+12V
11	+3.3V
12	-12V
13	GND
14	Power Supply On
15	GND
16	GND
17	GND
18	-5V
19	+5V
20	+5V

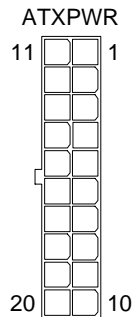

BACK PANEL PORTS

The back panel has the following ports:

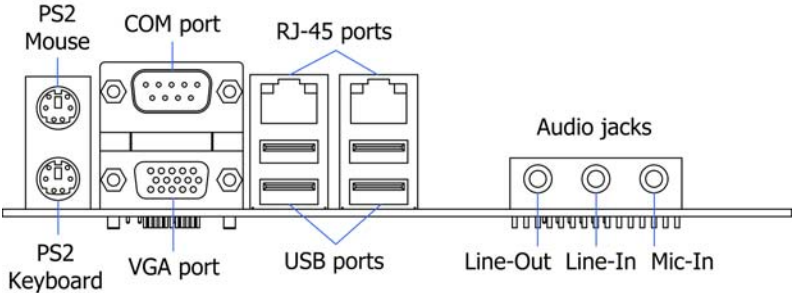

Mouse and Keyboard

The connector above is for a PS/2 mouse, and the one below is for a PS/2 keyboard.

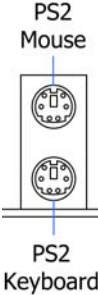

Serial port: COM

The 9-pin COM port is for pointing devices or other serial devices.

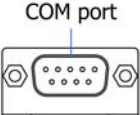

VGA Port

The 15-pin female VGA connector can be used to connect to any analog VGA monitor.

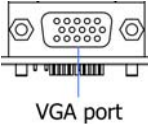

RJ45 10/100 LAN and USB Connectors

The mainboard provides a standard RJ-45 and USB 2.0 ports. These ports allow connection to a Local Area Network (LAN) through a network hub and USB 2.0 devices.

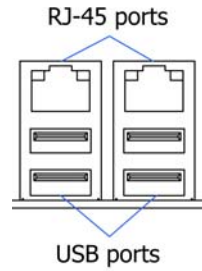

Audio Port

The Line-Out jack is for connecting to external speakers or headphones. The Line-In jack is for connecting to an external audio device such as a CD player, tape player, etc. The Mic jack is for connecting to a microphone.

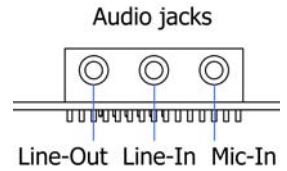

Note:

The audio ports can be switched to Smart 5.1 6-channel audio output. You can enable the function by clicking the “Vinyl Audio” icon on your desktop after installing the audio driver.

After completing the previous installation, connect the speakers to the 3-jack connectors on the back panel.

CONNECTORS

Hard Disk Connectors: IDE1

The mainboard has a 32-bit Enhanced IDE and Ultra DMA 133/100/66 controller that provides PIO mode 0~4, Bus Master, and Ultra DMA 133/100/66 functions. You can connect up to four hard disk drives, CD-ROM and other devices.

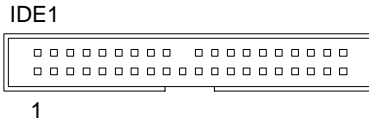

Serial ATA Connectors: SATA1 and SATA2

These next generation connectors support the thin Serial ATA cables for primary internal storage devices. The current Serial ATA interface allows up to 150MB/s data transfer rate, faster than the standard parallel ATA with 133 MB/s (Ultra DMA).

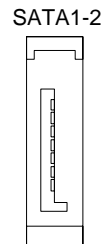

USB Pin Connector: USB

The mainboard provides one USB pin header, allowing up to 2 additional USB2.0 ports up to maximum throughput of 480 Mbps. Connect each 2-port USB cable into this pin header. This port can be used to connect high-speed USB interface peripherals such as USB HDD, digital cameras, MP3 players, printers, modem and the like.

Pin	Signal
1	VUSB0
3	USB_D_T0-
5	USB_D_T0+
7	GND
9	Key

Pin	Signal
2	VUSB0
4	USB_D_T1-
6	USB_D_T1+
8	GND
10	GND

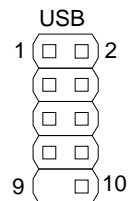

Case Connector: F_PANEL

The F_PANEL pin header allows you to connect the power switch, reset switch, power LED, sleep LED, HDD LED and the case speaker.

Pin	Signal
1	+PWR_LED
3	+PWR_LED
5	-PWR_LED
7	SPEAK+
9	NC
11	NC
13	SPEAK-
15	Key

Pin	Signal
2	+HD_LED
4	-HD_LED
6	PW_BN
8	GND
10	RST_SW
12	GND
14	+SLEEP_LED
16	-SLEEP_LED

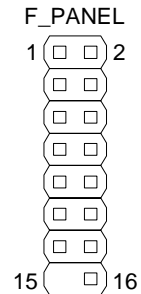

Power Switch (PW_BN)

Connect to a 2-pin power button switch. Pressing this button will turn the system power on or off.

Reset Switch (RST_SW)

The reset switch is used to reboot the system rather than turning the power ON/OFF. Avoid rebooting the system, if the HDD is still working. Connect the reset switch from the system case to this pin.

Power LED (-PLED)

The LED will light when the system is on. If the system is in S1 (POS - Power On Suspend) or S3 (STR - Suspend To RAM) state, the LED will blink.

HDD LED (HD_LED)

HDD LED shows the activity of a hard disk drive. Avoid turning the power off when the HDD LED still has a lit. Connect the HDD LED from the system case to this pin.

Speaker

The speaker from the system case is connected to this pin.

Front Panel Audio Connector: F_AUDIO

This is an interface for the VIA front panel audio cable that allow convenient connection and control of audio devices. By default, the pins labeled LINE_OUT_R/NEXT_R and the pins LINE_OUT_L/NEXT_L are shorted with jumper caps. Remove the caps only when you are connecting the front panel audio cable.

Pin	Signal	Pin	Signal
1	MICIN_L	2	AUD_GND
3	MICIN_R	4	-PRESENSE
5	HPOUT_R	6	AUD_RET_R
7	FRONT_IO_SENSE	8	Key
9	HPOUT_L	10	AUD_RET_L

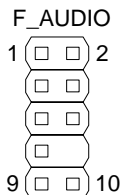

Note:

If you don't want to connect to the front audio header, pins 5 & 6, 9 & 10 have to be jumpered in order to have signal output directed to the rear audio ports. Otherwise, the Line-Out connector on the back panel will not function.

Consumer Infrared Module / PS2 Header: CIR / KBMS

The mainboard provides a CIR pin header. It is also convertible to a KBMS pin header which is to attach a PS/2 keyboard and mouse.

Pin	Signal	Pin	Signal
1	+5VDUAL	2	GND
3	KB_CLK	4	KB_DATA
5	EXT_KBCLK	6	EXT_KBDATA
7	MS_CLK	8	MS_DATA
9	EXT_MSCLK	10	EXT_MSDATA

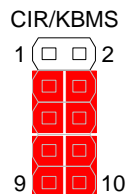

Note: When the pin header is not in use, please short pin 3&5, pin 4&6, pin 7&9, and pin 8&10.

Serial Port Connectors: COM2, COM3, and COM4

COM2/3/4 pin headers can be used to attach additional ports for serial mouse or other serial devices.

Pin	Signal
1	DCD
3	TXD
5	GND
7	RTS
9	RI

Pin	Signal
2	RXD
4	DTR
6	DSR
8	CTS
10	Key

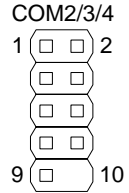

Digital I/O Connector: DIO

General purpose input and output for POS systems.

Pin	Signal
1	5V_DIO
3	GPO_21
5	GPO_22
7	GPO_32
9	GPO_33
11	GND

Pin	Signal
2	12V_DIO
4	GPI_44
6	GPI_45
8	GPI_46
10	GPI_47
12	GND

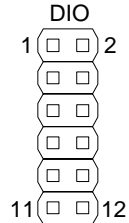

LPC Connector: LPC

This pin connector is for LPC devices.

Pin	Signal
1	LAD1
3	-PCIRSTX
5	LAD0
7	LAD2
9	SERIRQ
11	-LDRQ1
13	+5V
15	+5V
17	GND
19	GND

Pin	Signal
2	LPC_33_CLK
4	GND
6	SIO_48_OSC
8	-LFRAME
10	LAD3
12	-EXTSMI
14	+3.3V
16	+3.3V
18	GND
20	Key

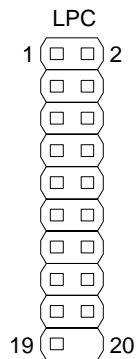

LPT Connector: LPT

The mainboard provides a 26-pin connector to be able to connect a 25-pin female external connector for LPT (parallel port). A parallel port is a standard printer port that supports Enhanced Parallel Port (EPP) and Extended Capabilities Parallel Port (ECP) modes.

Pin	Signal
1	-LP_STB
3	LP_D0
5	LP_D1
7	LP_D2
9	LP_D3
11	LP_D4
13	LP_D5
15	LP_D6
17	LP_D7
19	-LP_ACK
21	LP_BUSY
23	LP_PE
25	LP_SLCT

Pin	Signal
2	-LP_AFD
4	-LP_ERR
6	-LP_INIT
8	-LP_SLIN
10	GND
12	GND
14	GND
16	GND
18	GND
20	GND
22	GND
24	GND
26	Key

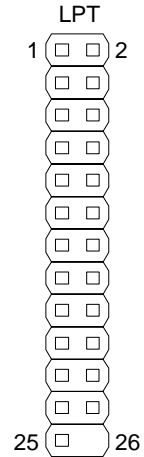

LVDS Panel Connector: PANEL

The LVDS Panel connector allow you to connect the panel's LVDS cable directly to support LVDS panel without any need of a daughter card.

Pin	Signal
1	-LD2C4
3	+LD2C4
5	GND
7	-LD2C5
9	+LD2C5
11	GND
13	-LD2C6
15	+LD2C6
17	GND
19	-LCLK2
21	+LCLK2
23	GND
25	-LD2C7
27	+LD2C7
29	NC
31	NC
33	NC
35	NC
37	NC
39	NC

Pin	Signal
2	PVDD
4	PVDD
6	GND
8	GND
10	-LD1C0
12	+LD1C0
14	GND
16	-LD1C1
18	+LD1C1
20	GND
22	-LD1C2
24	+LD1C2
26	GND
28	-LCLK1
30	+LCLK1
32	GND
34	-LD1C3
36	+LD1C3
38	SMB_DAT
40	SMB_DAT

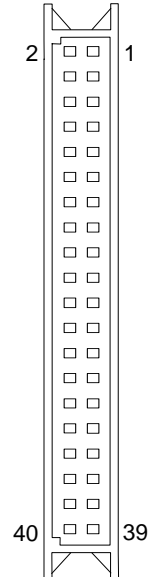

Inverter Connector: INVERTER

The mainboard provides an inverter for supplying power to the backlight of the LCD panel.

Pin	Signal
1	IVDD
2	IVDD
3	BLON
4	NC
5	BLON
6	BR_CNTR
7	GND
8	GND



MFX Pin connector

This pin connector is for MFX-01 add-on cards. This pin header also allows you to connect SMBus (System Management Bus) devices (using pins 4, 6, and 8). Such devices communicate with an SMBus host and/or other SMBus devices using the SMBus interface.

Pin	Signal
1	+5V
3	PW_BN
5	NC
7	NC
9	GND

Pin	Signal
2	+5VSUS
4	SMB_CLK
6	SMB_DAT
8	GND
10	Key

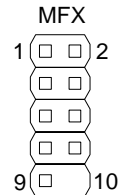

TV Connector: TV

This pin connector allows you to connect to a TV set.

Pin	Signal
1	Y (Y, G)
3	Pr (C, R)
5	Pb (CVBS, B)

Pin	Signal
2	GND
4	Key
6	GND

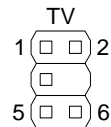

JUMPERS

The mainboard provides jumpers for setting some mainboard functions. This section will explain how to change the settings of the mainboard functions using the jumpers.

Clear CMOS: CLEAR_CMOS

The onboard CMOS RAM stores system configuration data and has an onboard battery power supply. To reset the CMOS settings, set the jumper on pins 2 and 3 while the system is off. Return the jumper to pins 1 and 2 afterwards. Setting the jumper while the system is on will damage the mainboard.

Setting	1	2	3
Clear CMOS setting	OFF	ON	ON
Keep CMOS setting	ON	ON	OFF

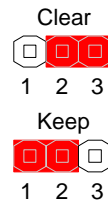

WARNING: Except when clearing the RTC RAM, never remove the cap on CLEAR_CMOS jumper default position. Removing the cap will cause system boot failure. Avoid clearing the CMOS while the system is on; it will damage the mainboard.

Voltage Selector for COM Connectors: J1/2/3

This VCC selector is to determine the input voltage of each COM connector.

Setting	1	2	3
+5V	ON	ON	OFF
+12V	OFF	ON	ON

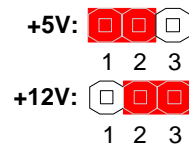

Inverter Selector: IVDD_SEL

IVDD is the VCC selector jumper to determine the input voltage of the panel inverter for panel's back-light.

Setting	1	2	3
+5V	ON	ON	OFF
+12V	OFF	ON	ON

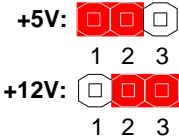

Panel Power Selector: PVDD_SEL

PVDD is the VCC selector jumper to determine the panel's signal voltage.

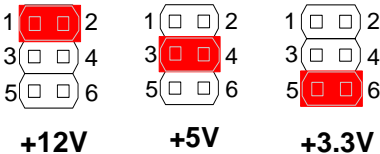

Setting	1	2	3	4	5	6
+12V	ON	ON	OFF	OFF	OFF	OFF
+5V	OFF	OFF	ON	ON	OFF	OFF
+3.3V	OFF	OFF	OFF	OFF	ON	ON

SLOTS

Peripheral Component Interconnect: PCI

The PCI slot allows you to insert PCI expansion card. When adding or removing expansion card, unplug first the power supply. Read the documentation for the expansion card if any changes to the system are necessary.

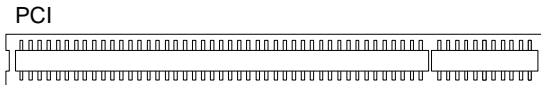

PCI Interrupt Request Routing

The IRQ (interrupt request line) are hardware lines over which devices can send interrupt signals to the microprocessor. The "PCI & LAN" IRQ pins are typically connected to the PCI bus INT A# ~ INT D# pins as follows:

	Order 1	Order 2	Order 3	Order 4
PCI Slot 1	INT B#	INT C#	INT D#	INT A#

CHAPTER 3

BIOS Setup

This chapter gives a detailed explanation of the BIOS setup functions.

ENTERING SETUP

Power on the computer and press <Delete> during the beginning of the boot sequence to enter the BIOS setup menu. If you missed the BIOS setup entry point, you may restart the system and try again.

CONTROL KEYS

Keys	Description
Up Arrow	Move to the previous item
Down Arrow	Move to the next item
Left Arrow	Move to the previous tab
Right Arrow	Move to the next tab
Enter	Select the item
Escape	Jumps to the Exit menu or returns to the main menu from a submenu
+	Increase the numeric value
-	Decrease the numeric value
F1	General help, only for Status Page Setup Menu and Option Page Setup Menu
F7	Discard Changes
F9	Load Optimized defaults
F10	Save all the changes and exit

GETTING HELP

The BIOS setup program provides a “General Help” screen. You can display this screen from any menu/sub-menu by pressing <F1>. The help screen displays the keys for using and navigating the BIOS setup. Press <Esc> to exit the help screen.

MAIN MENU

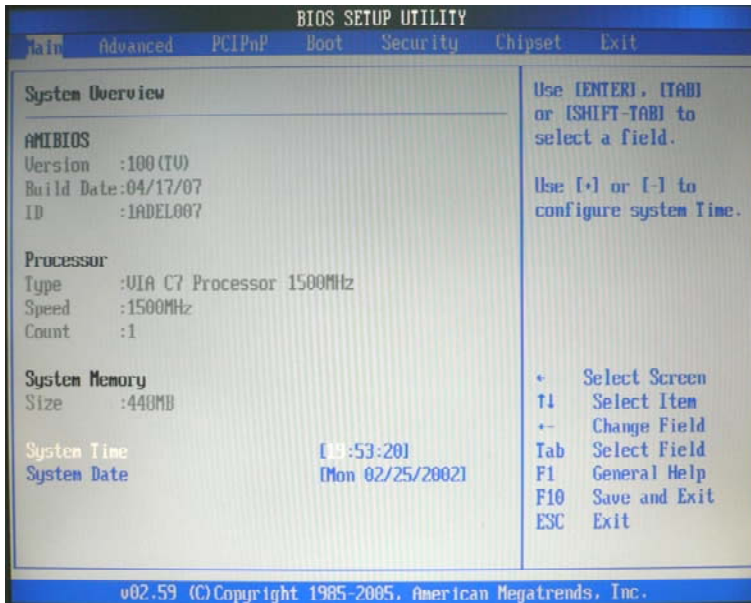

AMIBIOS

BIOS version number and related information.

Processor

CPU information.

System Memory

Memory size.

System Time

Use the key "+" or "-" to configure system time. The time format is [Hour : Minute : Second].

System Date

Use the key "+" or "-" to configure system Date. The date format is [Day, Month, Date, Year].

ADVANCED SETTINGS

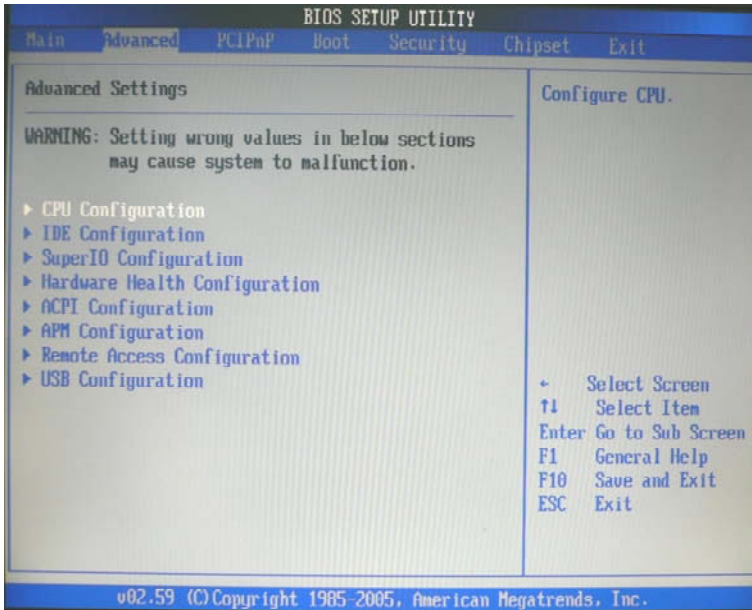

CPU Configuration

IDE Configuration

Super I/O Configuration

Hardware Health Configuration

ACPI Configuration

APM Configuration

Remote Access Configuration

USB Configuration

CPU CONFIGURATION

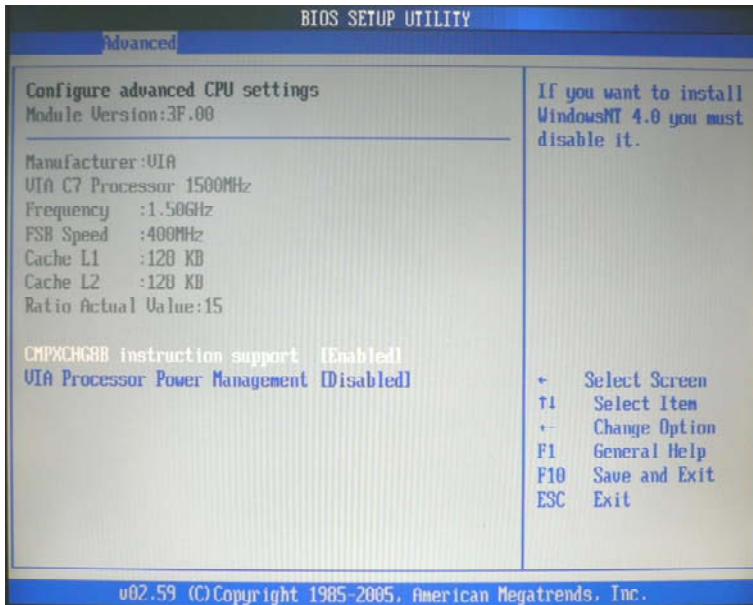

CMPXCHG8B instruction support

Settings: [Enabled, Disabled]

VIA Processor Power Management

Setting	Description
Enabled	This selection enables CPU speed to be adjustable according to system loads in order to lower power consumption.
Disabled	Disable the function and CPU will be working in high speed.

IDE CONFIGURATION

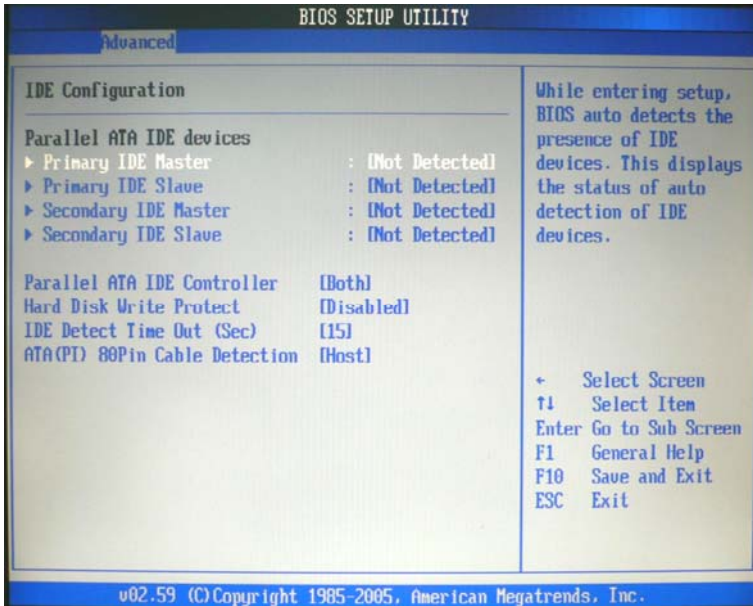

Parallel ATA IDE Controller

Settings: [Disabled, Primary, Secondary, Both]

Hard Disk Write Protect

Settings: [Enabled, Disabled]

IDE Detect Time Out (Sec)

Settings: [0, 5, 10, 15, 20, 25, 30, 35]

ATA(P) 80Pin Cable Detection

Settings: [Host & Device, Host, Device]

IDE DRIVES

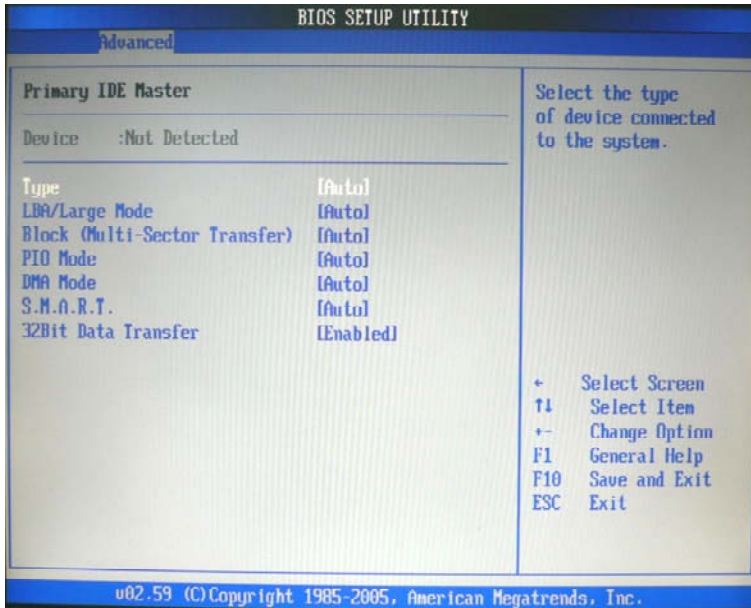

Type

Settings: [Not Installed, Auto, CD/DVD, ARMD]

LBA/Large Mode

Settings: [Disabled, Auto]

Block (Multi-Sector Transfer)

Settings: [Disabled, Auto]

PIO Mode

Settings: [Auto, 0, 1, 2, 3, 4]

DMA Mode

Settings: [Auto]

S.M.A.R.T.

Self Monitoring Analysis and Reporting Technology, a monitoring system for hard disks.

Settings: [Auto, Enabled, Disabled]

32Bit Data Transfer

Settings: [Enabled, Disabled]

SUPER I/O CONFIGURATION

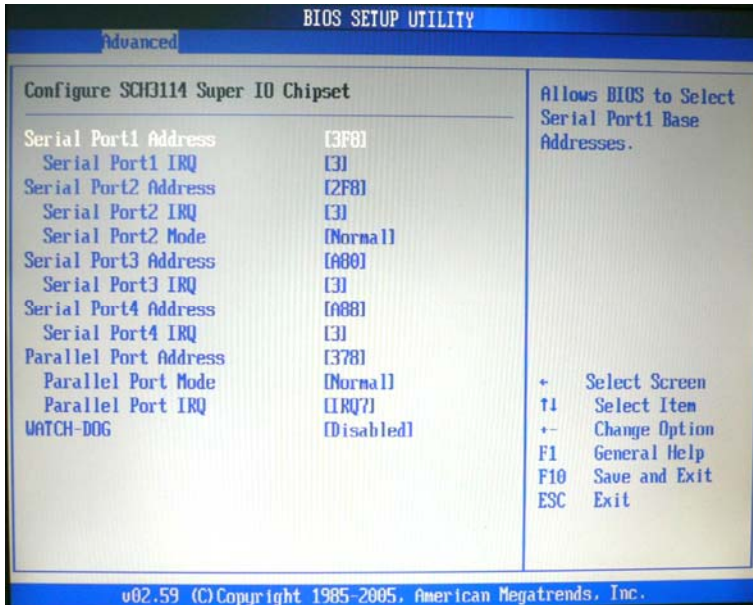

Serial Port1 Address

Settings: [Disabled, 3F8, 3E8, 2E8]

Serial Port1 IRQ

Settings: [3, 4, 10, 11]

Serial Port2 Address

Settings: [Disabled, 2F8, 3E8, 2E8]

Serial Port2 IRQ

Settings: [3, 4, 10, 11]

Serial Port2 Mode

Settings: [Normal, IrDA, ASK IR]

Serial Port3 Address

Settings: [Disabled, A80, A88, A90, A98, AA0, AA8]

Serial Port3 IRQ

Settings: [3, 4, 10, 11]

Serial Port4 Address

Settings: [Disabled, A80, A88, A90, A98, AA0, AA8]

Serial Port4 IRQ

Settings: [3, 4, 10, 11]

Parallel Port Address

Settings: [Disabled, 378, 278, 3BC]

Parallel Port Mode

Settings: [Normal, SPP (Bi-Dir), EPP+SPP, ECP, ECP+EPP]

Parallel Port IRQ

Settings: [IRQ5, IRQ7]

WATCH-DOG

Settings: [Disabled, Enabled]

HARDWARE HEALTH CONFIGURATION

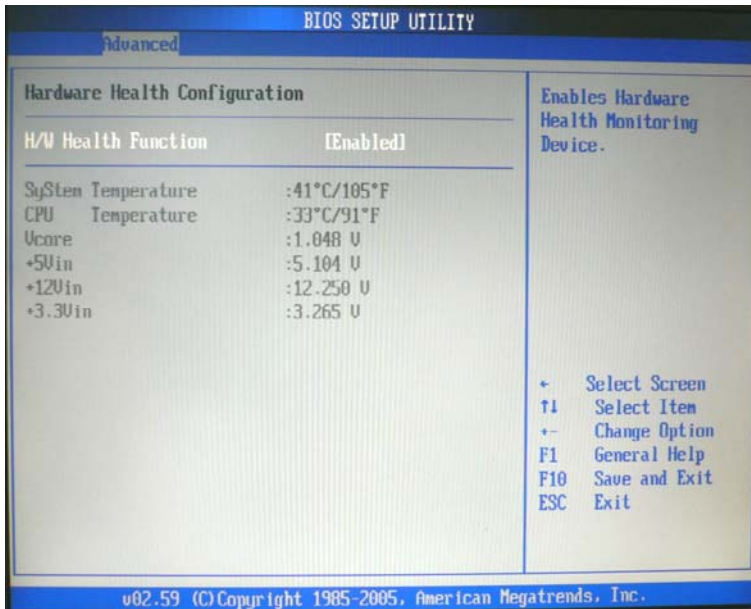

Hardware Health Configuration

This item is used to enable or disable hardware health monitoring device.

Settings: [Enabled, Disabled]

ACPI SETTINGS

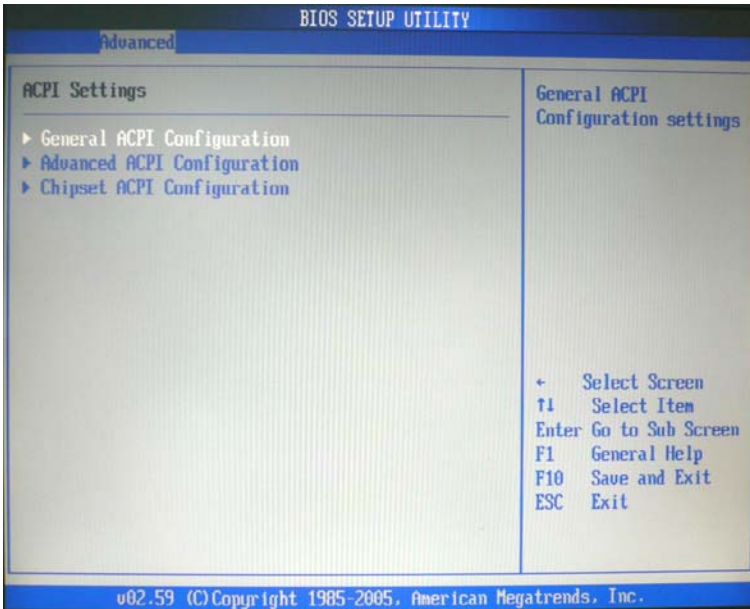

General ACPI Configuration

This menu contains ACPI (Advanced Configuration and Power Management Interface) options.

Advanced ACPI Configuration

Chipset ACPI Configuration

GENERAL ACPI CONFIGURATION

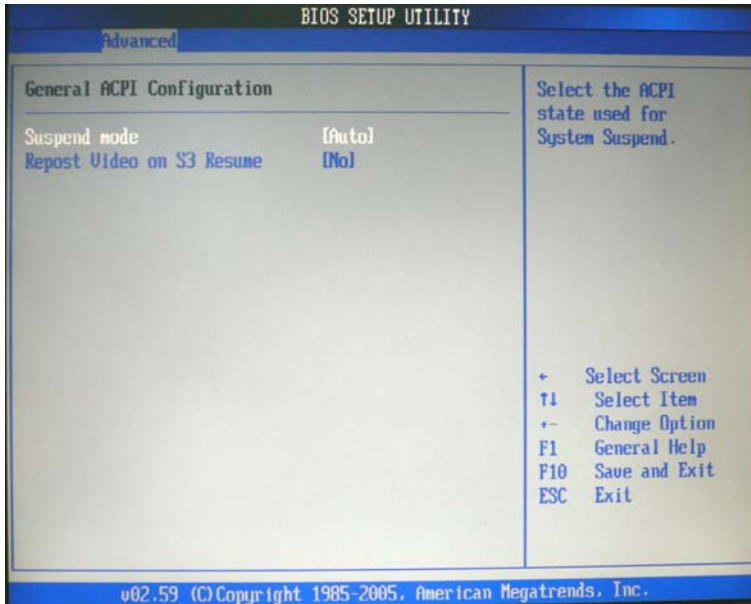

Suspend mode

Select the ACPI state used for system suspend.

Setting	Description
S1(POS)	S1/Power On Suspend (POS) is a low power state. In this state, no system context (CPU or chipset) is lost and hardware maintains all system contexts.
S3(STR)	S3/Suspend To RAM (STR) is a power-down state. In this state, power is supplied only to essential components such as main memory and wakeup-capable devices. The system context is saved to main memory, and context is restored from the memory when a "wakeup" event occurs.
Auto	Depends on the OS to select the state.

Repost Video on S3 Resume

To determine whether to invoke VGA BIOS post on S3/STR resume or not.

Settings: [No, Yes]

ADVANCED ACPI CONFIGURATION

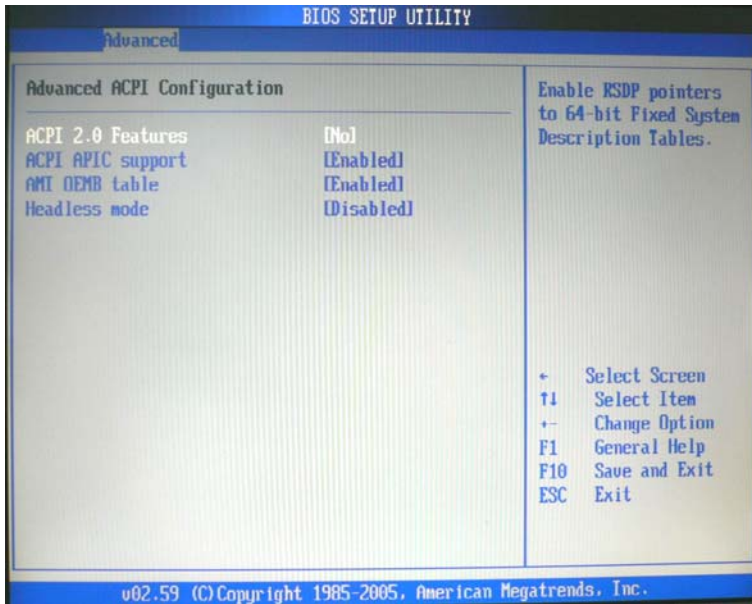

ACPI 2.0 Features

To enable RSDP pointers to 64-bit Fixed System Description Tables.

Settings: [No, Yes]

ACPI APIC support

To include ACPI APIC table pointer to RSDT pointer list.

Settings: [Enabled, Disabled]

AMI OEMB Table

To include OEMB table pointer to R(X)SDT pointer lists.

Settings: [Enabled, Disabled]

Headless Mode

To enable or disable headless operation mode through ACPI.

Settings: [Enabled, Disabled]

CHIPSET ACPI CONFIGURATION

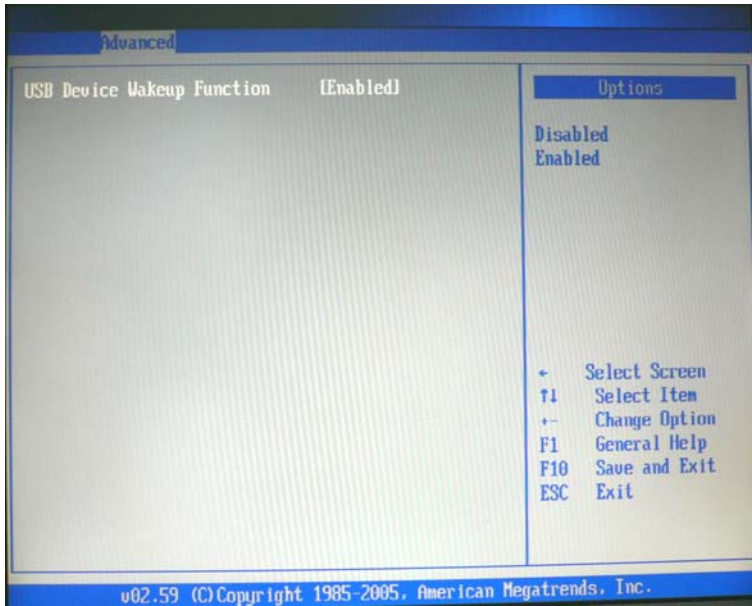

USB Device Wakeup Function

Settings: [Enabled, Disabled]

APM CONFIGURATION

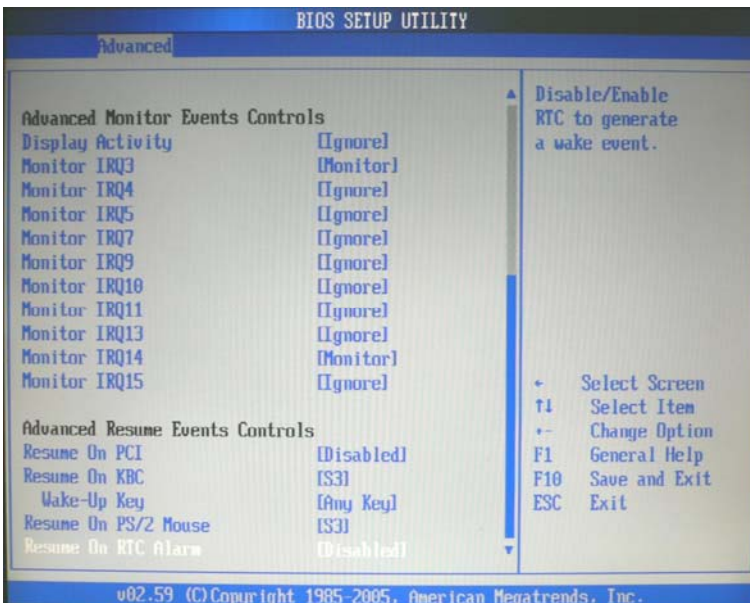
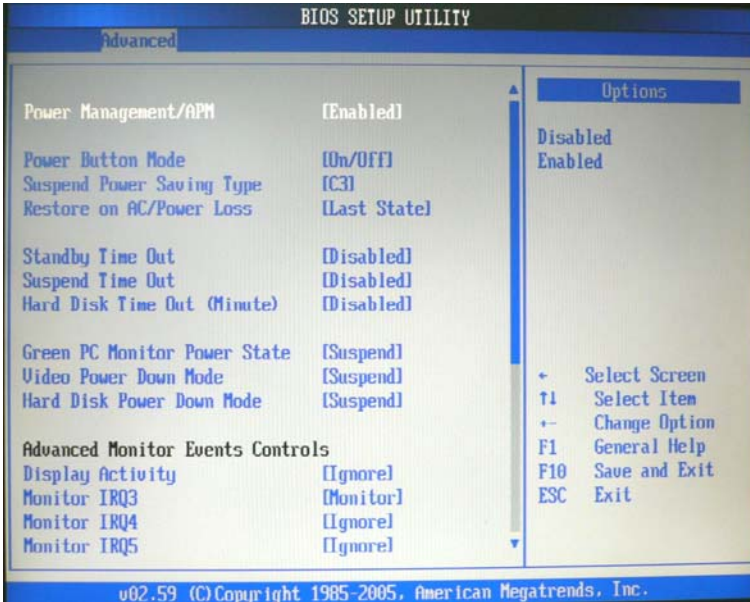

Power Management / APM

Settings: [Disabled, Enabled]

Power Button Mode

Settings: [On/Off, Standby, Suspend]

Suspend Power Saving Type

Settings: [C3, S1]

Restore on AC / Power Loss

The field defines how the system will respond after an AC power loss during system operation.

Setting	Description
Power Off	Keeps the system in an off state until the power button is pressed.
Power On	Restarts the system when the power is back
Last state	Save in last state

Standby Time Out

Settings: [Disabled, 1/2/4/8/10/20/30/40 minutes]

Suspend Time Out

Settings: [Disabled, 1/2/4/8/10/20/30/40 minutes]

Hard Disk Time Out

Settings: [Disabled, 1/2/3/4/5/6/7/8 minutes]

Green PC Monitor Power State

Settings: [Standby, Suspend, Off]

Video Power Down Mode

Settings: [Disabled, Standby, Suspend]

Hard Disk Power Down Mode

Settings: [Disabled, Standby, Suspend]

Display Activity

Settings: [Ignore, Monitor]

Monitor IRQ3~15

Enables or disables the monitoring of the specified IRQ line.

Settings: [Ignore, Monitor]

Note:

IRQ (Interrupt Request) lines are system resources allocated to I/O devices. When an I/O device needs to gain attention of the operating system, it signals this by causing an IRQ to occur. After receiving the signal, when the operating system is ready, the system will interrupt itself and perform the service required by the IO device.

Resume on PCI

Settings: [Disabled, Enabled]

Resume on KBC

Settings: [Disabled, S3, S3/S4/S5]

Wake-up Key

Settings: [Any Key, Specific Key]

Resume on PS/2 Mouse

Enables any mouse activity to restore the system from the power saving mode to an active state.

Settings: [Disabled, S3, S3/S4/S5]

Resume on RTC Alarm

Sets a scheduled time and/or date to automatically power on the system.

Settings: [Disabled, Enabled]

REMOTE ACCESS CONFIGURATION

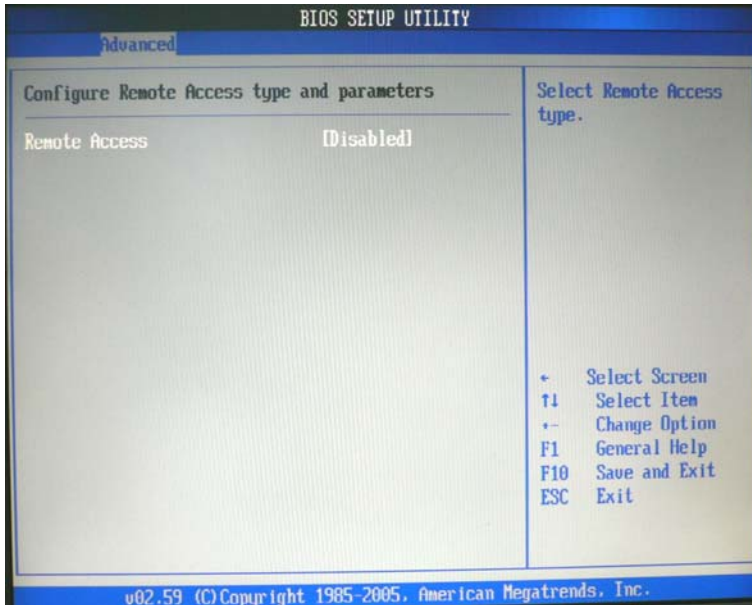

Remote Access

To select Remote Access type.

Settings: [Disabled, Enabled]

USB CONFIGURATION

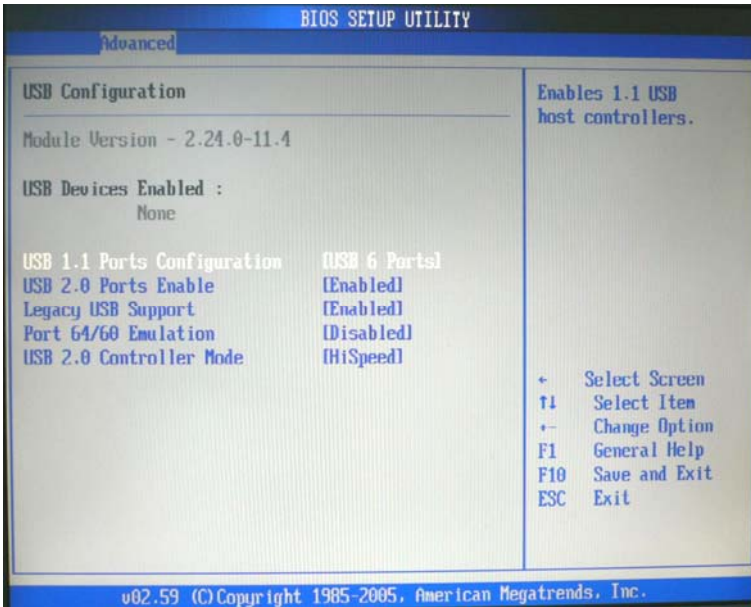

USB 1.1 Ports Configuration

To enable USB 1.1 host controllers.

Settings: [Disabled, USB 2 ports, USB 4 ports, USB 6 ports]

USB 2.0 Ports Enable

To enable USB 2.0 host controllers.

Settings: [Disabled, Enabled]

Legacy USB Support

To enable support for legacy USB.

Settings: [Disabled, Enabled, Auto]

Port 64/60 Emulation

To enable I/O port 60h/64h emulation support.

Settings: [Disabled, Enabled]

USB 2.0 Controller Mode

To configure the USB 2.0 controller in HiSpeed (480Mbps) or FullSpeed (12Mbps).

Settings: [HiSpeed, FullSpeed]

ADVANCED PCIPNP SETTINGS

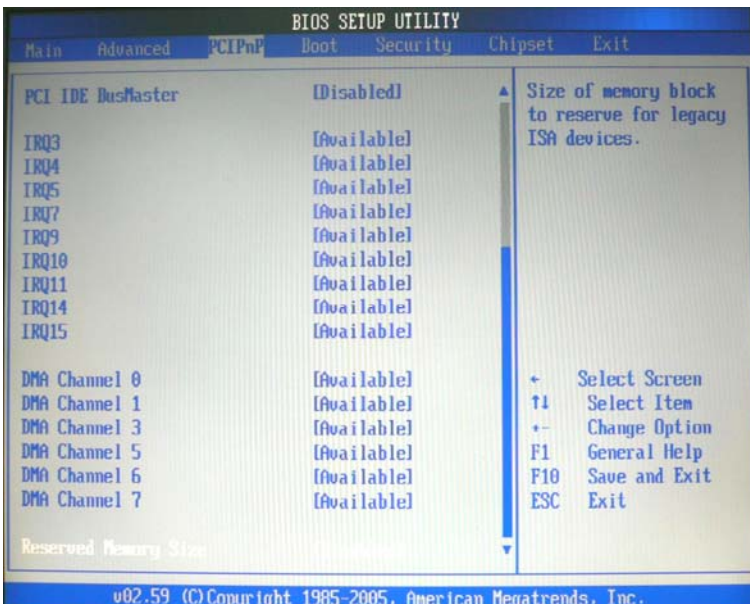
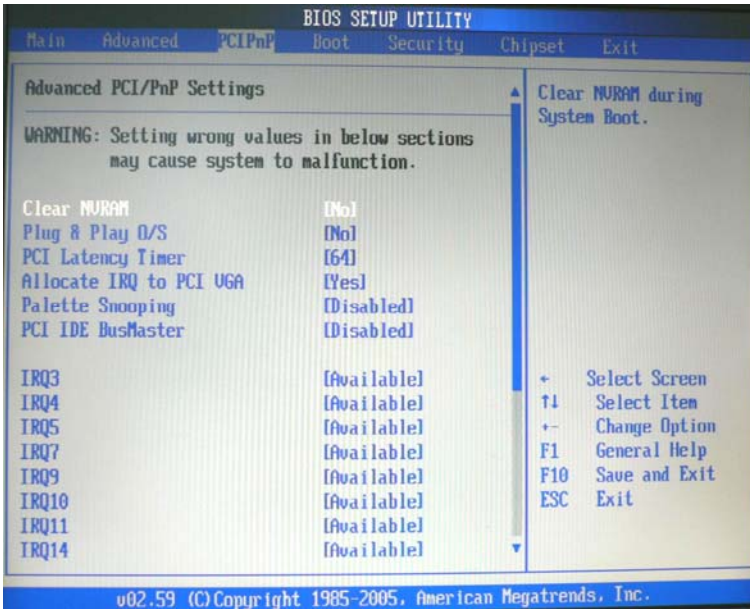

Note:

This section covers some very technical items and it is strongly recommended to leave the default settings as it is unless you are an experienced user.

Clear NVRAM

To clear NVRAM during system boot.

Settings: [No, Yes]

Plug & Play O/S

Settings: [No, Yes]

PCI Latency Timer

Value in units of PCI clocks for PCI device latency timer register.

Settings: [32, 64, 96, 128, 160, 192, 224, 248]

Allocate IRQ to PCI VGA

Settings: [No, Yes]

Palette Snooping

Settings: [Disabled, Enabled]

PCI IDE BusMaster

Settings: [Disabled, Enabled]

IRQ3~15

Settings: [Available, Reserved]

DMA Channel 0~7

Settings: [Available, Reserved]

Reserved Memory Size

To decide the size of memory block to reserve for legacy ISA devices.

Settings: [Disabled, 16k, 32k, 64k]

BOOT SETTINGS

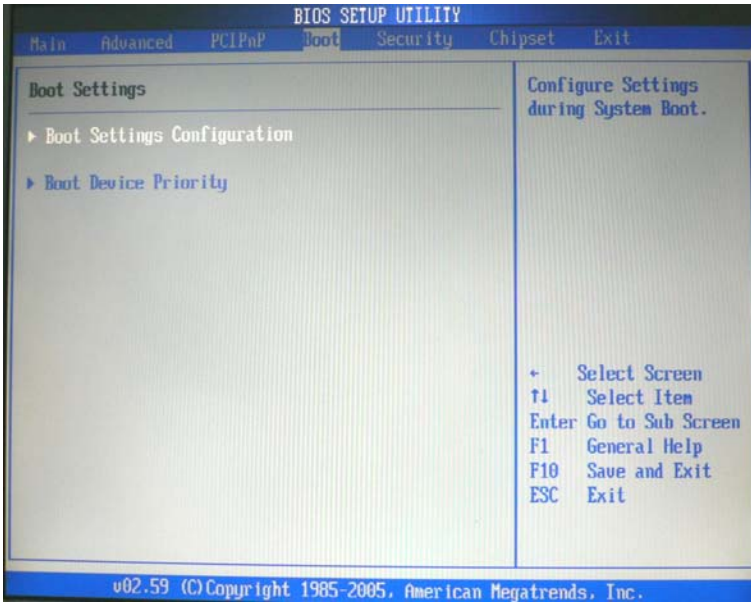

Boot Settings Configuration

Configuration settings during system boot.

Boot Devices Priority

Specifies the boot device priority sequence.

BOOT SETTINGS CONFIGURATION

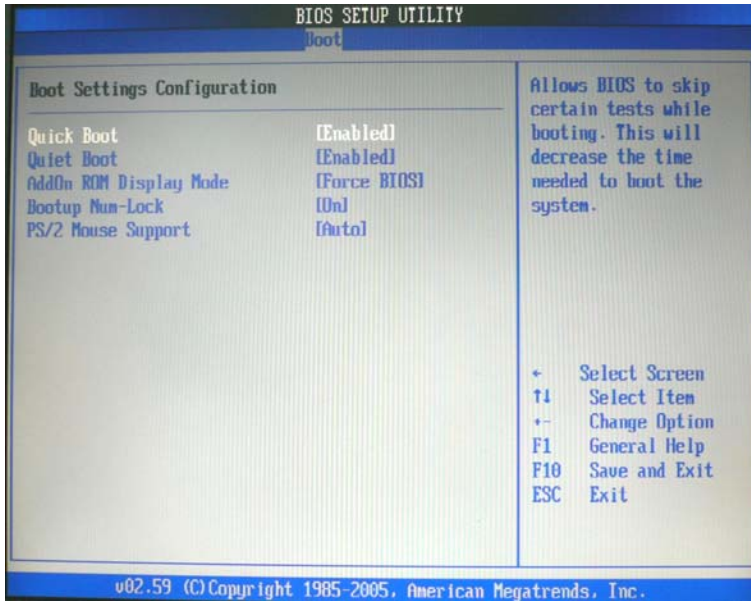

Quick Boot

Settings: [Disabled, Enabled]

Quiet Boot

Settings: [Disabled, Enabled]

AddOn ROM Display Mode

Settings: [Force BIOS, Keep Current]

Bootup Num-Lock

To select power-on state for Num-Lock.

Settings: [Off, On]

PS/2 Mouse Support

Settings: [Disabled, Enabled, Auto]

BOOT DEVICE PRIORITY

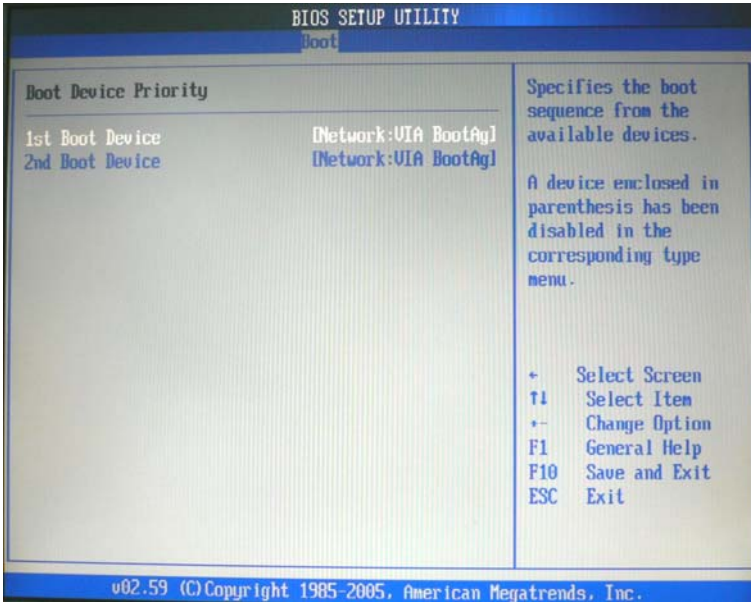

1st Boot Device

To specifies the boot sequence from the available devices. The available boot devices are detected dynamicly according to real situation and variable options will be provided.

Settings: [Network:VIA BootAgent, Disabled]

2nd Boot Device

Settings: [Network:VIA BootAgent, Disabled]

SECURITY SETTINGS

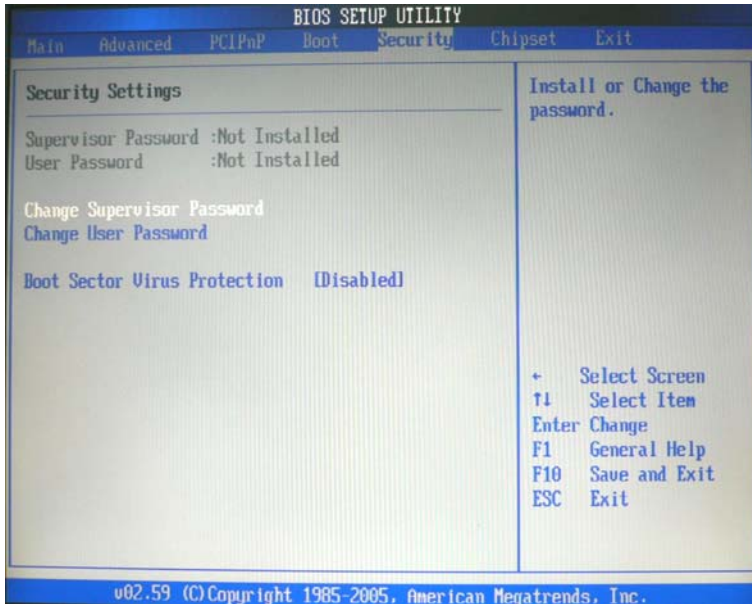

Change Supervisor Password

This option is for setting a password for entering BIOS Setup. When a password has been set, a password prompt will be displayed whenever BIOS Setup is run. This prevents an unauthorized person from changing any part of your system configuration.

When a supervisor password is used, the BIOS Setup program can be accessed and the BIOS settings can be changed.

Change User Password

When a user password is used, the BIOS Setup program can be accessed but the BIOS settings cannot be changed.

Boot Sector Virus Protection

Settings: [Disabled, Enabled]

ADVANCED CHIPSET SETTINGS

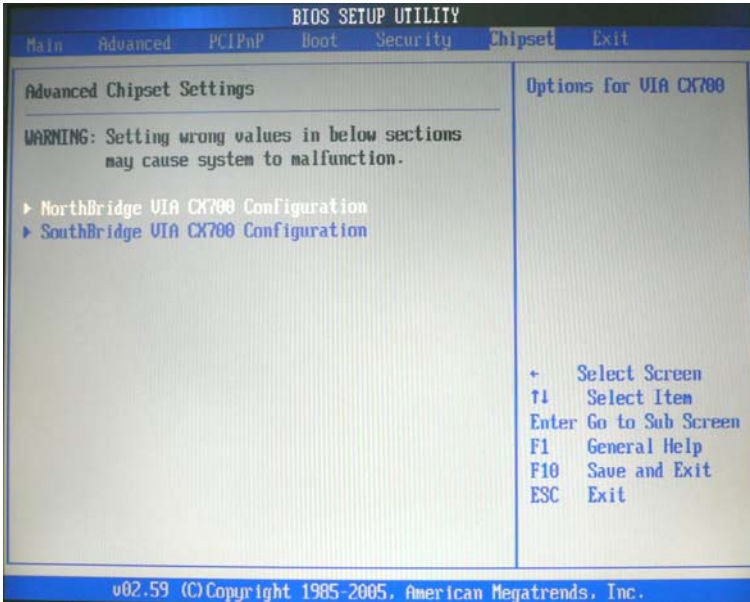

WARNING: The Advanced Chipset Settings menu is used for optimizing the chipset functions. Do not change these settings unless you are familiar with the chipset.

NorthBridge VIA CX700 Configuration

SouthBridge VIA CX700 Configuration

NORTHBRIDGE VIA CX700 CONFIGURATION

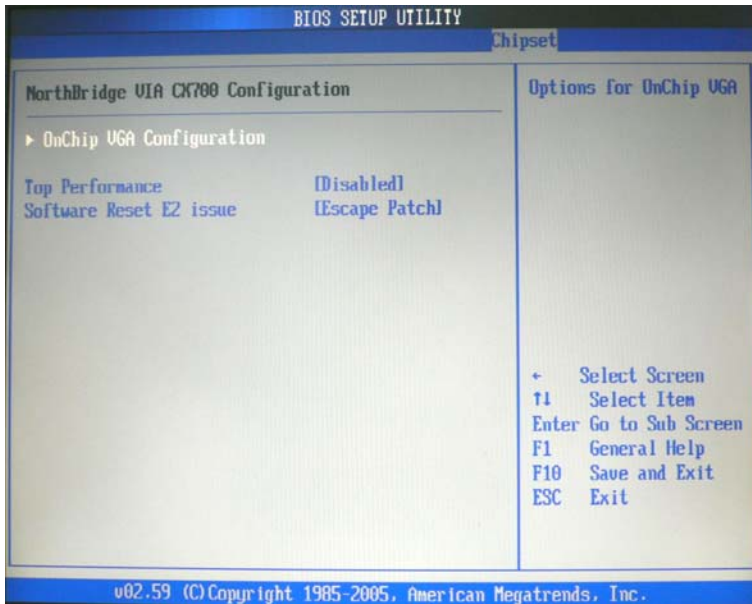

Top Performance

Settings: [Disabled, Enabled]

Software Reset E2 issue

Settings: [Patch, Escape Patch]

ONCHIP VGA CONFIGURATION

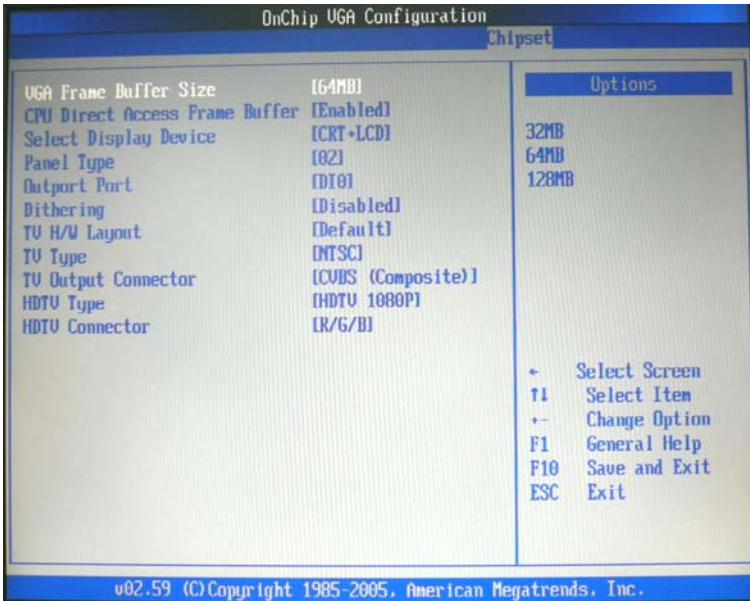

VGA Frame Buffer Size

Settings: [32MB, 64MB, 128MB]

CPU Direct Access Frame Buffer

Settings: [Disabled, Enabled]

Select Display Device

Settings: [CRT, LCD, TV, HDTV, CRT+LCD, LCD+TV]

Panel Type

Settings: [02]

Outport Port

Settings: [D10, D11]

Dithering

Settings: [Disabled, Enabled]

TV H/W Layout

Settings: [Default, Composite+S-Video, S-Video+S-Video, Comp.+R/G/B, Comp.+Y/Cb/Cr, Comp.+SDTV-R/G/B, Comp.+SDTV-Y/Pb/Pr, Composite, S-Video]

TV Type

Settings: [NTSC, PAL/PAL B/PAL G/PAL H, PAL M, PAL N, PAL Nc, PAL I, PAL D, NTSC Japan]

TV Output Connector

Settings: [CVBS (Composite), S-Video 0 (Y/C), R/G/B, Cr/Y/Cb, SDTV-R/G/B, SDTV-Pr/Y/Pb, S-Video 1 (Y/C)]

HDTV Type

Settings: [SDTV 525I/480I NTSC, SDTV 625I/576I PAL, HDTV 480P/525P NTSC, HDTV 576P/625P/ PAL, HDTV 720P, HDTV 1080I, HDTV 1080P]

HDTV Connector

Settings: [R/G/B, Pr/Y/Pb]

SOUTHBRIDGE VIA CX700 CONFIGURATION

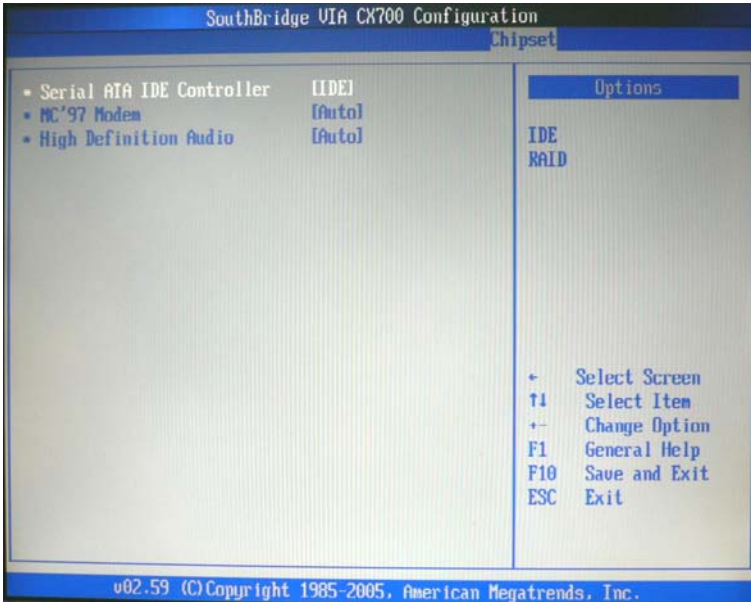

Serial ATA IDE Controller

Settings: [IDE, RAID]

MC'97 Modem

Settings: [Disabled, Auto]

High Definition Audio

Settings: [Disabled, Auto]

EXIT OPTIONS

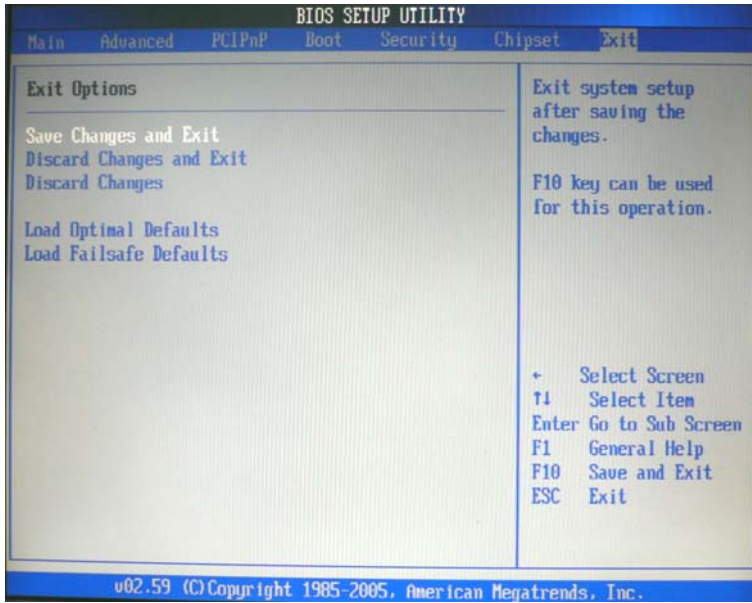

Save Changes and Exit

Exit system setup after saving the changes, or press "F10".

Discard Changes and Exit

Exit system setup without saving any changes, or press "Esc".

Discard Changes

Discard changes which have been done so far to any of the setup questions, or press "F7".

Load Optimal Defaults

Load optimal default values for all the setup items, or press "F9". The default optimized values are set by the mainboard manufacturer to provide a stable system with optimized performance.

Load Failsafe Defaults

Load fail-safe default values for all the setup items, or press "F8". The values are set by the mainboard manufacturer to provide basic system performance.

CHAPTER 4

Driver Installation

This chapter gives you brief descriptions of each mainboard driver and application. You must install the VIA chipset drivers first before installing other drivers such as audio or VGA drivers. The applications will only function correctly if the necessary drivers are already installed.

DRIVER UTILITIES

Getting Started

The Driver Utilities CD contains the driver utilities and software for enhancing the performance of the mainboard.

Note:

The driver utilities and software are updated from time to time. The latest updated versions are available at [http://www.viaembedded.com./](http://www.viaembedded.com/)

Running the Driver Utilities CD

To start using the CD, insert the CD into the CD-ROM or DVD-ROM drive. The CD should run automatically after closing the CD-ROM or DVD-ROM drive. The driver utilities and software menu screen should then appear on the screen. If the CD does not run automatically, click on the "Start" button and select "Run..." Then type: "D:\Setup.exe".

Note:

D: might not be the drive letter of the CD-ROM/DVD-ROM in your system.

CD CONTENT

- ☒ **VIA 4in1 Drivers:** Contains VIA ATAPI Vendor Support Driver (enables the performance enhancing bus mastering functions on ATA-capable Hard Disk Drives and ensures IDE device compatibility), AGP VxD Driver (provides service routines to your VGA driver and interface directly to hardware, providing fast graphical access), IRQ Routing Miniport Driver (sets the system's PCI IRQ routing sequence) and VIA INF Driver (enables the VIA Power Management function).
- ☒ **VIA Graphics Driver:** Enhances the onboard VIA graphic chip.
- ☒ **VIA Audio Driver:** Enhances the onboard VIA audio chip.
- ☒ **VIA USB 2.0 Driver:** Enhances VIA USB 2.0 ports.
- ☒ **VIA LAN Driver:** Enhances the onboard VIA 10/100M LAN chip.
- ☒ **VIA RAID Driver:** Support for SATA RAID devices.

Note:

EPIA-LT does not support video outputs of HDTV (YPbPr) and LCD. Please DO NOT enable these functions in this system.